



TOWN COUNCIL AGENDA REGULAR MEETING

THURSDAY
MARCH 20, 2025 – 2:00 P.M.

TOWN COUNCIL CHAMBERS
4300 S. ATLANTIC AVENUE, PONCE INLET, FL

SUNSHINE LAW NOTICE FOR BOARD MEMBERS – Notice is hereby provided that one or more members of the Town’s various boards may attend and speak at this meeting.

A complete copy of the materials for this agenda is available at Town Hall.

1. CALL TO ORDER.
2. PLEDGE OF ALLEGIANCE.
3. ROLL CALL.

NOTE: Citizens who wish to speak during Public Participation about any subject that is not on the meeting agenda should fill out the Citizen Participation Request form and submit it to the Town Clerk prior to the start of the meeting.

4. ADDITIONS, CORRECTIONS OR DELETIONS TO THE AGENDA.

5. CITIZENS’ PARTICIPATION - *The Town of Ponce Inlet encourages engagement by citizens via a variety of means. This is an opportunity for our citizens to talk to us collectively on any subject that is not identified on the meeting agenda. The Town’s Rules for Conducting Town Council meetings are set forth in Resolution 2024-09 and include the following guidelines:*

- *Citizens are provided with **5 minutes** at each meeting to speak on one or more issues that are not otherwise placed on the meeting agenda.*
- *Please introduce yourself with your name and address clearly for the record.*
- *Share with us your thoughts, ideas, and opinions; we want to hear them.*
- *Under our rules, all questions and comments are directed to the Mayor.*

While some questions may be able to be addressed at this meeting, others may require research or more information than we have readily available from our staff, so we may have to defer the response to you until we have that information. Also, depending on the type of issue, we may place the matter on a properly noticed subsequent meeting agenda. As a Council, we welcome the opportunity to hear from you and hope you will speak with us not only during Citizen Participation but outside of these meetings. We understand the formal nature of this meeting, but rest assured, we want to hear from you, we want to address your concerns, and we are appreciative of your involvement.

6. PROCLAMATIONS, PRESENTATIONS, AND AWARDS:

- A. Mayor’s Proclamation report.
- B. Certificates of Appreciation recognizing the Code Enforcement Board members for their years of service.

- C. Forerunner resilience and floodplain management software – *presented by Sophia Clavel*

7. CONSENT AGENDA - *Items on the consent agenda are defined as routine in nature that do not warrant detailed discussion or individual action by the Council; therefore, all items remaining on the consent agenda shall be approved and adopted by a single motion, second and vote by the Town Council. Items on the consent agenda are not subject to discussion. **Any member of the Town Council may remove any item from the consent agenda simply by verbal request at the Town Council meeting.** Removing an item from the consent agenda does not require a motion, second or a vote; it would simply be a unilateral request of an individual Council member and this item would then be added as the last item under New Business. As with all agenda items, the public will have the opportunity to comment prior to a motion being placed on the floor and their comment(s) may persuade the Council to remove the item from the Consent Agenda and place under New Business for discussion.*

- A. Approval of the Town Council Special meeting minutes. – February 12, 2025.
- B. Approval of the Town Council Regular meeting minutes. – February 20, 2025.

8. OLD/NEW BUSINESS ITEMS PREFERRED AT THE BEGINNING OF THE MEETING:

- A. Request for Co-Sponsorship of the Friends of the Marine Science Center’s *Seaside Spring Bazaar* event.
- B. Town of Ponce Inlet Podcast Name. – *presented by Becky Hugler*

9. PUBLIC HEARINGS / QUASI-JUDICIAL MATTERS: *None.*

10. PUBLIC HEARINGS / NON-QUASI-JUDICIAL MATTERS: *None.*

11. ORDINANCES (FIRST READING) AND RESOLUTIONS:

- A. Ordinance 2025-02 – 1st Reading – Amending the Land Acquisition Fund to allow the expenditure of funds for purposes other than public land acquisition and public facilities.
- B. Resolution 2025-02 – Extending the Sunset Date of the Public Safety Director *Pro Tem* position.

12. OLD BUSINESS: *None.*

13. NEW BUSINESS:

- A. Approval of Florida Power & Light (FPL) Agreement Designating the Town’s Community Center as a Staging Location.
- B. Acceptance of bid from Accurate Power and Technology, Inc. for the replacement Fire Station generator.

- C. Acceptance of bid from Alternative Current Electric for the replacement Public Works generator.
14. FROM THE TOWN COUNCIL:
- A. Vice-Mayor Smith, Seat #5
 - B. Councilmember Villanella, Seat #4
 - C. Councilmember White, Seat #3
 - D. Councilmember Milano, Seat #2
 - E. Mayor Paritsky, Seat #1
15. FROM THE TOWN MANAGER.
16. FROM THE TOWN ATTORNEY.
17. CITIZENS' PARTICIPATION - *The Town of Ponce Inlet encourages engagement by citizens via a variety of means. This is another opportunity for our citizens to talk to us collectively for **2 minutes** before closure of this meeting regarding reports provided by the Town Council, Town Manager, or Town Attorney in items 14-16 (only) of the meeting agenda.*
18. ADJOURNMENT.

Upcoming Town Council meeting(s) and Important date(s):

- Thursday, April 17, 2025, 2:00 PM – Regular Town Council Meeting.

*If a person decides to appeal any decision made by the Town Council with respect to any matter considered at a meeting or hearing, he/she will need a record of the proceedings and that for such purpose, he/she may need to ensure that a verbatim record of the proceedings is made, which record includes the testimony and evidence upon which the appeal is to be based. Persons who require accommodation to attend this meeting should contact the Ponce Inlet Town Hall at 236-2150 **at least 48 hours prior to the meeting** to request such assistance.*



Meeting Date: 3/20/2025

Agenda Item: 6

Report to Town Council

Topic: Proclamations, Presentations, and Awards.

Summary:

- A. Mayor's Proclamation report.
- B. Certificates of Appreciation recognizing the Code Enforcement Board members for their years of service.
- C. Forerunner resilience and floodplain management software.

Suggested motion: None required.

Requested by: Mayor Paritsky
Ms. Cherbano, Town Clerk
Mr. Lear, Planning & Development Director

Approved by: Mr. Disher, Town Manager



MEMORANDUM

Town of Ponce Inlet - Office of the Mayor

The Town of Ponce Inlet staff shall be professional, caring, and fair in delivering community excellence while ensuring Ponce Inlet citizens obtain the greatest value for their tax dollar.

To: Town Council
Through: Michael E. Disher, Town Manager
From: Mayor Lois A. Paritsky *LAP*
Date: March 12, 2025
Subject: Proclamation Report

The following Proclamation will be presented during this meeting:

- To urge all residents and businesses to help protect our precious water resources by practicing water saving measures and becoming more aware of the need to save water, I am presenting a Proclamation declaring the month of April, 2025 as *Water Conservation Month*.

A copy of the Proclamation may be viewed at the Town Hall kiosk.

PROCLAMATION OF THE TOWN OF PONCE INLET, FLORIDA

WHEREAS, water is a basic and essential need of every living creature; and

WHEREAS, the State of Florida, Water Management Districts and the Town of Ponce Inlet are working together to increase awareness about the importance of water conservation; and

WHEREAS, the Town of Ponce Inlet and the State of Florida have designated April, typically a dry month when water demands are most acute, Florida's Water Conservation Month, to educate citizens about how they can help save Florida's precious water resources; and

WHEREAS, the Town of Ponce Inlet has always encouraged and supported water conservation, through various educational programs and special events; and

WHEREAS, every business, industry, school, and citizen can make a difference when it comes to conserving water; and

WHEREAS, every business, industry, school, and citizen can help by saving water and thus promote a healthy economy and community; and

WHEREAS, efficient irrigation design, programming, and maintenance can conserve water, the Town of Ponce Inlet will encourage citizens and businesses to evaluate their irrigation systems for potential efficiency enhancements;

NOW, THEREFORE, I, Lois A. Paritsky, Mayor of the Town of Ponce Inlet, Florida, do hereby proclaim April 2025, as

WATER CONSERVATION MONTH

in the Town of Ponce Inlet and urge all residents and businesses to help protect our precious water resources by practicing water saving measures and becoming more aware of the need to save water. For this, the 27th year of Water Conservation Month, there will be a special focus on irrigation system evaluations.

IN WITNESS WHEREOF, I hereunto set my hand and cause the Seal of the Town of Ponce Inlet Florida, to be affixed this 20th day of March 2025.



Town of Ponce Inlet, Florida

Lois A. Paritsky
Lois A. Paritsky, Mayor

Attest:

Kim Cherbano
Kim Cherbano, CMC
Town Clerk



Meeting Date: 3/20/2025

Agenda Item: 7

Report to Town Council

Topic: Consent Agenda

- A. Approval of the Town Council Special meeting minutes. – February 12, 2025.
- B. Approval of the Town Council Regular meeting minutes. – February 20, 2025.

Summary: See attached documents.

Suggested motion: To approve the Consent agenda as presented.

Requested by: Ms. Cherbano, Town Clerk

Approved by: Mr. Disher, Town Manager



**Town of Ponce Inlet
Town Council
Special Meeting Minutes
February 12, 2025**

1 **1. CALL TO ORDER:** Pursuant to proper notice, Mayor Paritsky called the meeting to order
2 at 2:00 p.m. in the Council Chambers at 4300 South Atlantic Avenue, Ponce Inlet, Florida.

3
4 **2. PLEDGE OF ALLEGIANCE:** Mayor Paritsky led the Pledge of Allegiance.

5
6 **3. ROLL CALL:**

7 **Town Council:**

8 Mayor Paritsky, Seat #1

9 Councilmember Milano, Seat #2

10 Councilmember White, Seat #3

11 Councilmember Villanella, Seat #4

12 Vice-Mayor Smith, Seat #5

13
14 **Staff Members Present:**

15 Ms. Cherbano, Town Clerk

16 Mr. Disher, Town Manager

17 Ms. Gjessing, Assistant Deputy Clerk

18 Chief Glazier, Police Chief

19 Mr. Hooker, Code Compliance Manager

20 Ms. Hugler, Fire Department Office Manager/ PIO

21 Mr. Lear, Planning & Development Director

22 Mr. Okum, IT Director

23 Chief Scales, Public Safety Director

24 Attorney Shepard, Town Attorney

25 Ms. Stewart, Assistant Deputy Clerk

26
27 Mr. Lear provided a brief history of the Town Council's request for a more efficient code
28 enforcement process. He reviewed the timeline and procedures that have occurred since the initial
29 request. Two law firms responded to the Town's Request for Qualifications regarding a special
30 magistrate for code enforcement services, and representatives from both law firms were in
31 attendance to present their qualifications and answer questions.

32
33 **4. Presentation from Storch Law Firm.** – Mr. Glenn Storch, from Storch Law Firm,
34 provided a history on his 45 years as a practicing attorney and how he has represented code
35 enforcement cases through his tenure. He defined his perception of a special magistrate and
36 suggested ways to mediate cases and find solutions that benefit all. Mayor Paritsky asked what
37 sort of environment he would foster as the special magistrate; Mr. Storch stated he would like to
38 find solutions and educate individuals on violations without creating a feeling of disrespect to
39 anyone involved. She then asked how the firm's former or current clients in Ponce Inlet would
40 impact decisions made; Mr. Storch stated everyone would be treated the same according to the

41 code and no exceptions would be made for clients. Mayor Paritsky requested clarification on the
42 compensation rates and questioned whether there would be additional fees that were not set forth
43 in the proposal; Mr. Storch stated there would not be any additional fees. He stated he would be
44 the primary magistrate, and his partner Mr. Joey Posey would be the secondary magistrate.
45 Councilmember White requested clarification on potential conflicts of interest between clients and
46 Storch Law Firm; Mr. Storch stated the firm currently does not represent anyone in Ponce Inlet,
47 nor will they take on new clients in Town, if awarded the contract. Councilmember White asked
48 for an example of Mr. Storch's toughest code violation hearing that was resolved without litigation;
49 Mr. Storch recounted a story regarding a historic home being rebuilt. Mayor Paritsky opened
50 public participation – hearing none, public participation was closed.

51
52 **5. Presentation from Vose Law Firm, LLP.** – Mr. Wade Vose introduced himself and his
53 fellow attorney, Ms. Stephanie Velo from Vose Law Firm, LLP. He provided a summary of the
54 firm and their accumulated experience. He stated that local government representation is the
55 complete focus of their firm, and they do not represent developers or property owners who have
56 dealings with local governments in a development or code enforcement context. Ms. Stephanie
57 Velo introduced herself and provided a background on her experience. She stated she has extensive
58 experience litigating code enforcement lien foreclosures on behalf of local governments, she has
59 served as the hearing officer for other municipalities, and she has in-depth familiarity with assisting
60 Boards and Commissions in making legislative and quasi-judicial decisions in her ongoing role as
61 Town Attorney for another municipality. Ms. Velo elaborated on these points and illustrated how
62 she utilized this information in a particularly disruptive situation. Mayor Paritsky asked if someone
63 could address the firm's relationship with former clients. Mr. Vose explained that due to the firm's
64 long history of operations, they have had many different clients throughout the usual ebb and flow
65 of business; he elaborated further on the firm's dealings with Brooksville, FL and Naples, FL.
66 Mayor Paritsky and Councilmember White requested clarification on the compensation rates and
67 questioned whether there would be additional fees that were not set forth in the proposal. Mr. Vose
68 stated the Town would only be charged for Ms. Velo's time working on cases and they will not
69 charge for miscellaneous expenses such as travel time, copies, etc. A brief discussion ensued
70 regarding potential conflicts of interest between clients and Mr. Vose said the firm would not
71 represent residents in a private capacity. Councilmember White asked Ms. Velo for an example of
72 her toughest code violation hearing that was resolved without litigation; Ms. Velo provided an
73 anecdote of a negotiation where the best course of action for compliance of the violation was for
74 the homeowner to demolish an unpermitted addition to a home. Councilmember Villanella
75 questioned Ms. Velo's experience with waterfront property cases. A discussion followed regarding
76 naming an alternate magistrate as a back-up in the case of Ms. Velo's absence. Mayor Paritsky
77 opened public participation – Ms. Elena Richards, 54 Ocean Way Drive, questioned whether the
78 fee will change dependent on which attorney in the firm ultimately provides their services to the
79 Town in the case Ms. Velo is unavailable; Mr. Vose stated the maximum rate charged would be
80 Ms. Velo's rate of \$250 per hour. Mayor Paritsky closed public participation.

81
82 **6. Consideration of Storch Law Firm and Vose Law Firm, LLP in response to their**
83 **applications for RFQ 2024-04 – Special Magistrate for Code Enforcement Services.** –
84 Councilmember White asked about the Town Attorney's role in the Special Magistrate hearing
85 process; Attorney Shepard clarified the Town Attorney would continue to assist staff with code

86 enforcement cases and further explained the special magistrate’s role. Councilmember White and
87 Councilmember Villanella emphasized the importance of experience in a role such as this. There
88 was a brief discussion on whether the Councilmembers had a preference towards one of the firms
89 based on the proceedings. Mayor Paritsky opened public participation – Elena Richards, 54 Ocean
90 Way Drive, provided several comments, urging the Councilmembers to deliberate which firm will
91 better serve the Town’s needs while upholding the Town’s standards. Mr. Storch informed the
92 Council that he originally submitted a proposal to assist the Town, as he thinks fondly of Ponce
93 Inlet; he then formally withdrew Storch Law Firm’s proposal from consideration. Mayor Paritsky
94 thanked Storch Law Firm for their time and consideration.

95
96 Councilmember White moved to hire Vose Law Firm, LLP as a Special Magistrate for the Town
97 of Ponce Inlet; the motion was seconded by Councilmember Villanella. The motion PASSED 5-0,
98 with the following vote: Councilmember White – yes; Councilmember Villanella – yes; Mayor
99 Paritsky – yes; Councilmember Milano – yes; Vice-Mayor Smith – yes.

100
101 **7. ADJOURNMENT** – With no further business, Mayor Paritsky adjourned the meeting at
102 3:06 PM.

103
104 Respectfully submitted by:

105
106 Draft
107 Kim Cherbano, CMC / Town Clerk
108 Prepared by: Stephanie Gjessing, Assistant Deputy Clerk

109
110 Attachment(s): *None.*



Town of Ponce Inlet
Town Council
Regular Meeting Minutes
February 20, 2025

4

5
6
7
8
9
10
11
12
13
14
15
16
17
18
19
20
21
22
23
24
25
26
27
28
29
30
31
32
33
34
35
36
37
38
39
40
41
42
43
44
45

1. CALL TO ORDER: Pursuant to proper notice, Mayor Paritsky called the meeting to order at 2:00 p.m. in the Council Chambers at 4300 South Atlantic Avenue, Ponce Inlet, Florida.

2. PLEDGE OF ALLEGIANCE: Mayor Paritsky led the Pledge of Allegiance.

3. ROLL CALL:
Town Council:
Mayor Paritsky, Seat #1
Councilmember Milano, Seat #2
Councilmember White, Seat #3
Councilmember Villanella, Seat #4
Vice-Mayor Smith, Seat #5

Staff Members Present:
Ms. Alex, Cultural Services Manager
Ms. Cherbano, Town Clerk
Mr. Disher, Town Manager
Ms. Gjessing, Assistant Deputy Clerk
Chief Glazier, Police Chief
Ms. Hall, Assistant Finance Director
Ms. Hugler, Fire Department Office Manager/ PIO
Mr. Lear, Planning & Development Director
Ms. McColl, Finance Director
Mr. Okum, IT Director
Chief Scales, Public Safety Director
Attorney Shepard, Town Attorney
Mr. Wargo, Public Works Director

4. ADDITIONS, CORRECTIONS, OR DELETIONS TO THE AGENDA: An additional Proclamation was added to Item 6-A.

Mayor Paritsky moved to approve the agenda as amended; seconded by Councilmember Villanella; The motion PASSED 5-0, consensus.

5. CITIZENS PARTICIPATION: Mayor Paritsky opened citizens participation – Mr. Steve Field, 6 Mar Azul, recounted a recent occurrence in which he was accosted when riding his bike and told he was not allowed to ride on the sidewalk and would instead have to ride in the street; he stated the Police Chief assured him he did not have to ride in the street as there are no bike lanes in Ponce Inlet. Mr. Field also commented on parking and signage around the Town. Mr. Shannon White, 39 Coastal Oaks Circle, raised questions on projected growth rate and revenue

46 streams; a brief discussion ensued between Vice-Mayor Smith and Mr. White on how these
47 estimates impact projected revenue streams. Ms. Barbara Davis, Ponce Inlet resident, commented
48 on the Ponce Preservers luncheon and the Island Telegraph newsletter. Mr. John Carney, 38
49 Coastal Oaks Circle, reviewed the budget process and provided suggestions on changes to the
50 procedure including giving directions to work with a more constrained budget. Mayor Paritsky
51 closed citizens participation.
52

53 **6. PROCLAMATIONS, PRESENTATIONS, AND AWARDS:**

54
55 **A. Mayor’s Proclamation report.** – Mayor Paritsky presented a proclamation
56 declaring the week of March 3rd – March 9th, 2025 as *Flood Awareness Week*, and presented a
57 proclamation declaring the month of February, 2025 as *Black History Month*.
58

59 **B. Proclamation – World Encephalitis Awareness Day.** – Mayor Paritsky presented
60 a proclamation declaring February 22nd, 2025 as *World Encephalitis Awareness Day*. Former Port
61 Orange Councilwoman Kat Atwood and her husband Ken Atwood provided information on raising
62 awareness around encephalitis. They described how encephalitis has impacted their lives and Ms.
63 Atwood announced there will be a conference devoted to encephalitis awareness in November.
64 Mayor Paritsky declared the Town Hall office will be lit up in red in honor of *World Encephalitis*
65 *Awareness Day* on February 22nd, 2025.
66

67 **C. Proclamation – Jim Hinson Day.** – Volusia County Council Vice-Chair Matt
68 Reinhart presented a proclamation declaring February 20, 2025 as *Jim Hinson Day* in honor of the
69 late Mr. Jim Hinson.
70

71 **D. Proclamation – North Turn’s Historic Legends Parade Day.** – Volusia County
72 Council Vice-Chair Matt Reinhart presented a proclamation declaring February 20, 2025 as
73 *Historic North Turn Legends Parade Day*.
74

75 **E. Proposal to construct a kayak launch at the Jesse Linzy boat ramp.** – Mr. Tom
76 Rutledge presented his proposal, stating that with the increase in traffic at the Ponce Inlet boat
77 ramp, he has noticed a significant amount of people using the ramp for paddle boards and kayaks.
78 He explained his safety concerns regarding this usage and proposed a solution to accommodate
79 the kayakers and paddleboarders. His ideas include installing a floating dock, improving the
80 shoreline, reconfiguring the existing parking lot, and more. Mayor Paritsky asked whether the
81 Cultural Services Board had previously researched options around the boat ramp; Mr. Disher
82 explained that last year the Board had discussed creating a kayak launch staging area, and this
83 information could be provided to the Council at another meeting. Councilmember White
84 commented on future construction, funding, and the potential to use part of Lighthouse Point Park
85 for the launching area and extra parking. Mayor Paritsky opened public participation – Mr. Steve
86 Field, 6 Mar Azul, commented on the fee to enter Lighthouse Point Park and his concerns regarding
87 traffic around the boat launch. Ms. Barbara Davis, Ponce Inlet resident, expressed her interest in
88 the launch to be in Lighthouse Point Park. Mayor Paritsky closed public participation.
89

90 **F. Proposal for a “Rainbow Bridge” at Ponce’s Happy Tails Dog Park.** – Ms.
91 Debbie Darino explained that a “Rainbow Bridge” is a place for individuals to honor the memory

92 of their beloved pets, and have been installed in places around the country. She elaborated on the
93 bridge, the design, and its intended use, stating that people may place pet collars on the bridge, to
94 remind them of the beloved pet they lost. Ms. Darino stated Paul Culver Construction has
95 graciously offered to donate the bridge to the Town. Public Works would be responsible for
96 maintaining the bridge. Councilmember Milano suggested having the Cultural Services Board
97 review the proposal and make a recommendation to the Council.
98

99 Mayor Paritsky then invited Volusia County Council Vice-Chair Matt Reinhart to speak. Mr.
100 Reinhart provided an update on the County's efforts regarding dredging of the intercoastal
101 waterway. He stated the pre-dredging work will begin in March 2025, and provided information
102 on what that process will look like. The dredging itself is projected to begin in April 2025. An
103 estimated 900,000 cubic yards of beach-compatible sand is anticipated to be dredged from the inlet
104 and placed along the beaches to strengthen the shoreline. The schedule for sand placements can be
105 found at www.volusia.org. Vice-Chair Reinhart noted three upcoming public information sessions
106 hosted by the County regarding beach improvement planning and coastal resiliency.
107

108 **7. CONSENT AGENDA:** Mayor Paritsky asked if there was any item Council would like to
109 remove from the consent agenda; there were no requests. Mayor Paritsky asked if there were any
110 requests from the public – there were none.
111

112 **A. Approval of the Town Council Regular meeting minutes – January 16, 2025.**

113 **B. Request to declare Fire Department manual stretcher as surplus equipment.**

114 **C. Request for continued support for the S. Peninsula Drive Sidewalk Project.**
115
116
117

118 Mayor Paritsky moved to approve the Consent Agenda as presented; seconded by Councilmember
119 Villanella; The motion PASSED 5-0, consensus.
120

121 **8. OLD/NEW BUSINESS ITEMS PREFERRED AT THE BEGINNING OF THE**
122 **MEETING:**
123

124 **A. Discussion – Residential Parking Permit Program.** – Mr. Lear stated due to the
125 significant rise in visitors and traffic over the last several years, concerns among residents have
126 increased regarding parking availability and the overall impact on neighborhood quality of life.
127 Implementation of programs such as Volusia County's beach parking program have amplified
128 discussions for similar projects in Ponce Inlet. Mr. Huffine from Mead & Hunt provided a
129 presentation on residential parking permit programs and how one could potentially be
130 implemented in Ponce Inlet. He informed the Council on the project goals, the parking permits
131 study scope, the schedule, and potential parking management strategies. The Councilmembers
132 questioned if the company was aware of any grant opportunities for funding and whether the
133 projected program could be scaled back to focus further on Town specific needs. A discussion
134 ensued regarding what type of parking program would benefit the Town and how these could
135 potentially be implemented. Attorney Shepard commented on the legalities of parking restrictions.
136 Mayor Paritsky opened public participation – Mr. Shannon White, 39 Coastal Oaks Circle, asked
137 if the Town was attempting to become a gated community, how much the proposal would cost the

138 Town, suggested completing a cost-benefit analysis on the program, and commented on existing
139 ordinances. The Council discussed what they would like to see in the future regarding a residential
140 parking program. Mr. Huffine clarified their presentation was not costing the Town anything.
141 *[Editor’s note: The Town currently has a continuing services contract with Mead & Hunt. No*
142 *funds would be expended on this project unless first approved through a separate task order].* Mr.
143 White expressed his concern with contractors leaving sidewalks in disarray throughout the Town.

144
145 Council requested Mead & Hunt bring back information on the legality of parking restrictions on
146 public roads in residential areas along with available grant funding opportunities for the study.
147

148 **B. Request to partner with Embry-Riddle Aeronautical University to construct a**
149 **“living seawall” at Ponce Preserve.** – Mr. Disher provided the history of the request to construct
150 a “living seawall” at Ponce Preserve, noting discussion on this topic began on November 20, 2024
151 after a public workshop was held by Dr. Siddharth S. Parida about the benefits of the coastal
152 protection system. Dr. Parida, Assistant Professor with the Department of Civil Engineering at
153 Embry-Riddle Aeronautical University (ERAU), provided a presentation on using part of the
154 oceanfront shoreline of Ponce Preserve as a test site for living seawall technologies. He stated the
155 program is in Stage 2 of the grant process and elaborated on what the objectives and vision are.
156 He explained the three pillars of the program include the pilot project, long-term impact, and
157 scalability, sustainability and transferability. Dr. Parida provided renderings on how the
158 construction site is proposed for Ponce Preserve, how the long-term impact can be monitored, and
159 ways to engage other entities. Councilmember White questioned the use of coquina rock, the
160 impact on the existing stairs, and how this would coincide with the County’s ongoing beach
161 restoration project. Councilmember Milano asked about the length of the construction area and
162 whether it could be expanded in the future. Mayor Paritsky opened public participation – hearing
163 none, public participation was closed. Mr. Disher clarified how the funding would be allocated if
164 the Town were involved as a co-applicant and awarded the grant; the total amount being \$550,000.

165
166 Council consensus to support the use of the Ponce Preserve oceanfront shoreline for the “living
167 seawall” project and for the Town to join the NSF grant application, as evaluated by the Finance
168 Department.
169

170 **C. Appointment to the Cultural Services, Historic Preservation, & Tree Advisory**
171 **Board.** – Ms. Gjessing stated the Cultural Services, Historic Preservation, and Tree Advisory
172 Board consists of seven seats; the only seats currently vacant are Alternate Seats 1 and 2. Ms.
173 Kimberly Canny applied for appointment to the Board and informed staff she has reviewed the
174 training materials as required by the application. Mayor Paritsky opened public participation –
175 hearing none, public participation was closed.

176
177 Councilmember Villanella made a motion to appoint Ms. Kimberly Canny to Alternate Seat 1;
178 seconded by Councilmember Milano. The motion PASSED 5-0, consensus.
179

180 **D. Appointment to the Essential Services Advisory Board.** – Ms. Gjessing stated
181 the Essential Services Advisory Board consists of ten seats. Each seat requires a background in a
182 specific discipline, and the only seats currently available are Alternate Seat 2 (Fire-Rescue/EMS),
183 Alternate Seat 3 (Engineering), and Alternate Seat 4 (CPA/Financial). Mr. Matt Montgomery

184 applied for appointment to Seat 4, the CPA/Financial discipline. Mr. Montgomery informed staff
185 he has reviewed the training materials as required by the application and he has reviewed minutes
186 from previous meetings. Mayor Paritsky opened public participation – hearing none, public
187 participation was closed.

188
189 Councilmember Milano made a motion to appoint Mr. Matt Montgomery to Alternate Seat 4
190 (CPA/Financial); seconded by Councilmember White. The motion PASSED 5-0, consensus.

191
192 **E. Re-appointment of Chief J. Glazier to the Opioid Abatement Funding**
193 **Advisory Board.** – Chief Glazier explained his 2-year term on the Opioid Abatement Funding
194 Advisory Board expires on February 23, 2025. He briefly described the purpose of the Board and
195 the value it adds to the community. After originally being appointed by the Town Council, he is
196 seeking re-appointment to continue his term uninterrupted. Mayor Paritsky opened public
197 participation – hearing none, public participation was closed.

198
199 Council consensus to re-appoint Chief J. Glazier to the Opioid Abatement Funding Advisory
200 Board. The motion PASSED 5-0, consensus.

201
202 **9. PUBLIC HEARINGS / QUASI-JUDICIAL MATTERS:** *None.*

203
204 **10. PUBLIC HEARINGS / NON-QUASI-JUDICIAL MATTERS:** *None.*

205
206 **11. ORDINANCES (FIRST READING) AND RESOLUTIONS:** *None.*

207
208 **12. OLD BUSINESS:**

209
210 **A. Consideration of Town donation to the Volusia Tax Collector’s “Kids Tag**
211 **Art” program.** – Mr. Disher explained this item was first presented to the Town Council at last
212 month’s regularly scheduled meeting. He reviewed the program’s services in which students
213 design vanity license plates, the winning plate designs are sold, and the funds are used to support
214 arts education in participating schools. Mr. Disher reviewed the Town’s official policy for
215 charitable donations and stated that should the Council decided to provide a donation to this
216 program, the total amount should not exceed \$750, per Resolution 2008-02. Mayor Paritsky
217 opened public participation – hearing none, public participation was closed.

218
219 Councilmember Milano made a motion to support the “Kids Tag Art” program with a \$750
220 donation; seconded by Councilmember Villanella. The motion PASSED 5-0, consensus.

221
222 **13. NEW BUSINESS:**

223
224 **A. Cost-participation agreement with Harbour Village CSA for public-access**
225 **dune walkover.** – Mr. Lear reviewed the history of the cost-participation request with Harbour
226 Village CSA, noting that the Town Council approved adding it to the FY 24/25 budget on August
227 22, 2024. The Council’s approval was conditioned on signage being installed indicating the
228 walkover is publicly accessible and that the cost was not to exceed \$22,987.50. It was noted at that
229 time the arrangement would be need to memorialized in a separate agreement between the Town

230 and the CSA. He stated the subject agreement has been reviewed and approved by the Town
231 Attorney and addresses the Council’s concerns about liability and maintenance obligations. The
232 agreement states that the funds will not be provided until after the walkover has been constructed
233 and passed inspection by the Town. . Mayor Paritsky opened public participation – hearing none,
234 public participation was closed.

235
236 Councilmember White made a motion to approve the Harbour Village dune walkover cost-
237 participation agreement, as endorsed and budgeted by the Town Council in the FY 24/25 budget;
238 seconded by Councilmember Milano. The motion PASSED 5-0, consensus.

239
240 **B. Special Magistrate agreement for Code Enforcement services.** – Mr. Lear stated
241 at the Special Town Council meeting on February 12, 2025, which was held to consider the
242 applicants for the Special Magistrate for code enforcement services, the Town Council approved
243 the hiring of Vose Law Firm, LLP. The agreement is for a two-year term and has been reviewed
244 and approved by the Town Attorney. Attorney Shepard recommended naming a back-up
245 magistrate in the agreement, noting that the magistrate service will be provided by specific people,
246 not by the law firm as whole. Mayor Paritsky opened public participation – hearing none, public
247 participation was closed. Mr. Disher clarified the date for the agreement to be executed will be
248 after the Town’s final Code Enforcement Board meeting scheduled for February 24, 2025.

249
250 Councilmember Milano made a motion to approve the Special Magistrate Services Agreement
251 with Vose Law Firm, LLP and authorized the Mayor to execute the agreement, subject to adding
252 the name of an alternate magistrate as a back-up; seconded by Councilmember Villanella. The
253 motion PASSED 5-0, consensus.

254
255 **14. FROM THE TOWN COUNCIL:**

256
257 **A. Vice-Mayor Smith, Seat #5** – No further comments.

258
259 **B. Councilmember Villanella, Seat #4** – No further comments.

260
261 **C. Councilmember White, Seat #3** – Councilmember White reviewed information
262 from the recent Florida League of Mayor’s Roundtable. He explained the “Plug the Hole” program
263 which is a collaboration between St. Augustine Beach, St. John’s County, and the Florida
264 Department of Environmental Protection (FDEP). Councilmember White explained the program
265 allows St. Augustine Beach to bring in truckloads of sand to fill in the hole created by the beach
266 ramp. He requested support from the Council to present this program to the Volusia County Coastal
267 Division and the Volusia County Council.

268
269 Council consensus to support Councilmember White in presenting St. Augustine Beach’s “Plug
270 the Hole” program to the Volusia County Coastal Division and the Volusia County Council.

271
272 **D. Councilmember Milano, Seat #2** – Councilmember Milano provided an update
273 on the First-Step Shelter and stated 94% of those who completed the program are still in housing.
274 He also briefly compared the funding between the last couple of years.

275

276 **E. Mayor Paritsky, Seat #1** – Mayor Paritsky stated she attended the Florida League
277 of Cities’ Advocacy Committee meeting, and she reviewed some of the bills that were discussed.
278 She described House Bill 301 regarding sovereign immunity, House Bill 357 regarding property
279 tax exemptions, and Senate Bill 852 regarding a study to eliminate property taxes. She said her
280 next steps include gathering data from the Town to prove how the passing of these bills would
281 decrease the quality of life in the community and presenting this information to Volusia legislators
282 who can advocate on the Town’s behalf. Mayor Paritsky stated there will be an update at the next
283 regularly scheduled Town Council meeting on the proposed Town Wellness Program and the
284 underground utility cables. Regarding the State-sanctioned bear hunt, Mayor Paritsky informed
285 everyone that due to the absence of data related to this subject, she recommends drafting a letter
286 to the Florida Fish and Wildlife Commission (FWC) in lieu of a formal resolution. She elaborated
287 on her research and stated the solution is simply education and responsible waste management to
288 mitigate human-bear interactions. She requested Council’s support to attend the next FWC meeting
289 as representative of the Town to advocate against a state-sanctioned bear hunt.

290
291 Council consensus to support Mayor Paritsky to prepare a letter and attend the May 25th, 2025,
292 Florida Fish and Wildlife Conservation Commission’s meeting on behalf of the Town, urging them
293 to reinstate the prohibition on bear hunting throughout the State.

294
295 Mayor Paritsky stated as Chair of the Volusia Elected Officials, she created a subcommittee on
296 Stormwater Management and Flooding in the County; the subcommittee’s current mission
297 includes providing a repository for each municipality’s individual flooding problems, creating a
298 GIS map highlighting flooding “hot spots”, providing a comprehensive list of available hazard
299 mitigation funding for capital projects, and identifying regional projects.

300
301 **15. FROM THE TOWN MANAGER** – Mr. Disher provided information on addressing
302 stormwater-related issues and proposed ordinances designed to address these on-going issues, as
303 presented by Volusia County in recent meetings. He briefly described the berm restoration as part
304 of the US Army Corps of Engineers maintenance dredging and beneficial use project. Mr. Disher
305 mentioned Port Orange will be discussing the fluoridation of its potable water at their upcoming
306 meeting on March 18th; since Ponce Inlet purchases its water from Port Orange, he requested
307 Council direction to move forward with accumulating information on how this could impact
308 residents.

309
310 Council consensus to provide public notice to Ponce Inlet residents regarding Port Orange’s
311 upcoming March 18th meeting to discuss whether to continue fluoridation of the potable water,
312 and to collect and review the Town’s resident feedback on the matter.

313
314 Mr. Disher provided an update on activities from the Police, Cultural Services, and Public Works
315 departments. He stated there is a naming contest for Ponce Inlet’s new podcast series, and anyone
316 interested in submitting a nomination should look at the Town’s social media pages or email
317 rhugler@ponce-inlet.org.

318
319 **16. FROM THE TOWN ATTORNEY** – Attorney Shepard briefly described the potential
320 negative impacts that House Bill 301, related to sovereign immunity, could have if it passes.

321

322 Mr. Disher provided a quick update on the ongoing Septic-to-Sewer project. The town's federal
323 legislative delegation has begun to reach out to the Environmental Protection Agency (EPA) on
324 the Town's behalf regarding the eligibility of the project. At the recommendation of the Town's
325 lobbyist, a letter has also been sent to the new Deputy Director of EPA.

326
327 **17. PUBLIC PARTICIPATION (on items 14 – 16 only)** – Mayor Paritsky opened public
328 participation – hearing none, public participation was closed.

329
330 **18. ADJOURNMENT** – Mayor Paritsky adjourned the meeting at 4:57 PM.

331
332 Respectfully submitted by:

333
334 *Draft*

335 Kim Cherbano, CMC, Town Clerk
336 Prepared by: Stephanie Gjessing, Assistant Deputy Clerk
337 Attachment(s): *None*.

DRAFT



Meeting Date: 3/20/2025

Agenda Item: 8-A

Report to Town Council

Topic: Request for co-sponsorship of the Friends of the Marine Science Center's *Seaside Spring Bazaar* event.

Summary: The request for co-sponsorship of the Friends of the Marine Science Center's *Seaside Spring Bazaar* event includes the waiver of the special event permit fee (\$150). The applicant meets the currently adopted criteria for event co-sponsorship.

Suggested motion: Staff recommends approval of the request for co-sponsorship as the criteria have been met.

Requested by: Ms. Alex, Cultural Services Manager

Approved by: Mr. Disher, Town Manager



MEMORANDUM

TOWN OF PONCE INLET, CULTURAL SERVICES DEPARTMENT

The Town of Ponce Inlet staff shall be professional, caring and fair in delivering community excellence while ensuring Ponce Inlet citizens obtain the greatest value for their tax dollar

To: Michael E. Disher, AICP, Town Manager
 From: Jackie Alex, Cultural Services Manager
 Date: March 6, 2025
 Subject: Request for Co-Sponsorship of the Friends of the Marine Science Center's *Seaside Spring Bazaar* Event –April 5, 2025

MEETING DATE: March 20, 2025

The Friends of the Marine Science Center will be hosting the *Seaside Spring Bazaar* as a fundraiser for the Marine Science Center on Saturday, April 5, 2025, from 10:00am until 3:00pm. This event will be held at the Ponce Inlet Community Center, with vendors inside selling coastal-themed items. Because it will include food trucks, the event requires a Special Event permit from the Town. Although this is similar to their *Ocean Harvest Market* event hosted in September, 2024, this is the first year for the *Seaside Spring Bazaar*. The organizers anticipate up to 500 people throughout the five-hour timeframe. The Community Center holds its own liability insurance policy, of which the Town has a copy. The Friends of the Marine Science Center group is requesting co-sponsorship of this event for waiver of the special event permit fee (\$150). The co-sponsorship application also contains a request for waiver of Town personnel fees, but no personnel are needed for this event.

The Town's criteria for co-sponsorship approval are listed below.

Sec. 51-2. – Definitions: Town-sponsored event

Town-sponsored event means that the town, solely or as a co-sponsor of the event, produces and/or coordinates the event, or contributes town services, funds, staff, or aid of any kind as a co-sponsor, after determining that the event:

- (a) Is planned, organized, and conducted by the Ponce Inlet Community Center Board, Inc., or any established not-for-profit organizations and clubs based in Ponce Inlet, such as the Ponce Inlet Veterans Association, Ponce Inlet Lions Club, Ponce Inlet Garden Club, Ponce Inlet Women's Club, and the Ponce Inlet Art Guild, that annually provide a copy of their currently valid IRS tax exemption certificate as an established 501(c)3 organization; and/or
- (b) Has been traditionally co-sponsored by the Town as provided in Sec. 51-8(a).

Sec. 51-8(a)(1) & (2). – Co-sponsorship or co-sponsored event criteria and standards:

- (1) In addition to those long-standing events established by resolution, other events meeting the definition of *Town-sponsored event* under Sec. 51-2 may be approved by the town council in its sole discretion.

- (2) Full co-sponsorship for these events may include contributions of town services, funds, staff or aid of any kind as co-sponsor.

Pursuant to *Sec. 51-2.* and *Sec. 51-8(a)(1) & (2)*, the *Seaside Spring Bazaar* **does** meet the criteria for event co-sponsorship, as the Friends of the Marine Science Center is an established not-for-profit organization based in Ponce Inlet.

The request for co-sponsorship was submitted along with the special event permit application packet **(Attachment 1)**.

If the Town Council co-sponsors this event on the terms that the organizer is requesting, the total cost absorbed by the Town would be \$150 for the Special Event permit application fee.

SUMMARY:

Request for co-sponsorship of the Friends of the Marine Science Center's *Seaside Spring Bazaar* event scheduled for April 5, 2025; the request is for waiver of the special event permit fee (\$150).

RECOMMENDATION:

Staff recommends approval of the co-sponsorship request, as the criteria have been met.

Attachments:

1. Application Packet_2025 Seaside Spring Bazaar



Town of Ponce Inlet
Cultural Services Department
Request Form: Event Co-Sponsorship

Pursuant to Chapter 51 of the Code of Ordinances

This co-sponsorship request form must be filled out accurately and completely and submitted along with a special event permit application. Incomplete forms cannot be reviewed.

This form and all supporting documents **may be submitted up to 365 days in advance of the event, but no less than 60 days prior to the event date.** If the applicant desires their co-sponsorship request to be heard at a specific Town Council meeting, these documents must be submitted no less than **20 days prior to the desired Council meeting date.**

Request forms for co-sponsorship of eligible events will be presented to the Town Council for review if co-sponsorship has never been requested previously or if changes to a recurring event are proposed that would increase the costs incurred by the Town. Regardless of whether the event qualifies as a special event or is eligible for co-sponsorship, an applicant's co-sponsorship request shall comply with the content requirements below.

For event applicants requesting use of the Town's means of advertising, email jalex@ponce-inlet.org

Event Name: Seaside Spring Bazaar
Event Date(s): April 5, 2025 Event Location: PICCI
Business/ Organization Hosting Event: Friends of the Marine Science
Event Applicant/ Contact: Mindy Ash Center

Event (please select the one that best applies):

<input type="checkbox"/> Historic North Turn Legends Beach Parade
<input type="checkbox"/> Ponce Inlet Veterans Memorial Association Memorial Day
<input type="checkbox"/> Ponce Inlet Veterans Memorial Association Veterans Day
<input type="checkbox"/> Christmas Parade
<input type="checkbox"/> Planned, organized, and conducted by the Ponce Inlet Community Center Board, Inc.
Hosted by the following non-profit Ponce Inlet club or organization*: <input type="checkbox"/> Ponce Inlet Veterans Memorial Association <input type="checkbox"/> Ponce Inlet Lions Club <input type="checkbox"/> Ponce Inlet Garden Club <input type="checkbox"/> Ponce Inlet Women's Club <input type="checkbox"/> Ponce Inlet Art Guild <input checked="" type="checkbox"/> Other <u>Friends of the MSC</u>

*All non-profit Ponce Inlet clubs and organizations must annually provide a copy of their currently valid IRS tax exemption certificate as an established 501(c)3 status with a Ponce Inlet address.

Please provide a brief description of the event and any important details:

This is a fundraising event put on by the Friends Group for the MSC. It will have vendors selling their wares. There will also be 2 food trucks.

Please select your event needs and request for co-sponsorship:

Fees Incurred:	Town permission required:
<input checked="" type="checkbox"/> Waiver of Special Event permit fees	<input type="checkbox"/> Closure of boat ramp
<input checked="" type="checkbox"/> Waiver of Town personnel fees	<input type="checkbox"/> Closure of boat ramp trailer parking
<input type="checkbox"/> Waiver of Town Park pavilion rental fees	<input type="checkbox"/> Placement of temporary signs on Town property
	<input type="checkbox"/> Street closures
	<input type="checkbox"/> Use of Town facilities
	<input type="checkbox"/> Parking on Town property
Other: advertising	

1. Estimated number of event participants:

1000 ~~500~~

2. Estimated number of any animals by type:

0

3. Purpose of the event:

To raise money for the Marine Science Center's non-profit, the Friends Group & support mission of MSC
 & for the residents to engage in the community

4. Nature and the types of activities that will occur.

Vendor tables with items for sale
 Food trucks

5. Provide a copy of indemnification in favor of the Town and included as part of the application, which shall be executed by an authorized representative of the applicant. The organization will not be required to indemnify the Town for the negligent acts of the Town's employees or agents.

Attached

The applicant is the Ponce Inlet Community Center Board, Inc. and the Town has a copy

6. Describe any public right of way, property, buildings, facilities, or equipment utilized:

PICCI

7. County roadway is to be used:

Yes- County Right-of-Way Use Permit is attached

No

8. The event serves a valid public purpose benefiting the town and/ or its residents and the community by either-

Providing a local commemoration of a national holiday; or

Providing historical, educational, cultural enrichment and/or recreational experiences to Ponce

Inlet residents and the public.

Describe how:

This event will provide a special shopping experience to see what local vendors are creating & to support a local non profit benefiting the MSC & enjoy food trucks

As the applicant, I certify that upon request, I will provide event space or facilities to established Ponce Inlet organizations and clubs during the event without cost. (If granting of such space will constitute a bona fide undue hardship to the event organizer, the applicant shall include a waiver of this request in their co-sponsorship request along with the reason for the hardship on the bottom of page one of this form.)

Melinda C. Ash
Applicant signature

2-3-2025
Date

FOR OFFICE USE ONLY:

Application received by: Jackie Alex

Date: _____

Total Cost Incurred by Town: \$ _____

Waiver of Special Event Permit fees
Total Cost: 150

Waiver of Park Pavilion Rental fee
Total Cost: _____

Waiver of Town personnel fees
Total Cost: _____

Increase in costs since previous year:
 Yes Total: _____ No

Event needs requiring permission from Town:

- Closure of boat ramp
- Closure of boat ramp trailer parking
- Placement of temporary signs on Town property
- Street closures
- Use of Town facilities
- Parking on Town property
- Other: _____



Town of Ponce Inlet Special Event Checklist

Event Permit #: 148-2025

Bldg. Permit #:

Event Name: Seaside Spring Bazaar Invoice #: _____

Event Location: PICCI - 4670 S Peninsula Dr Event Description: FoMSC Fundraiser

Event Date(s): 04/05/2025 Event Hours: 10:00 am - 3:00 pm

Contact Name: Mindy Ash Phone: (847)-421-3539

Council Staff Report Due: 03/05/2025 Co-Sponsorship Town Property Event Use

Special Event Permit Application received 60 days prior to event date.

Application Packet Requirements	Required	Received
Amplified sound <i>(not required for in-town businesses)</i>	-	-
Building Permit Applications <input type="checkbox"/> Signs/ Banners <input type="checkbox"/> Tents <input type="checkbox"/> Stages/ Structures	-	-
Mobile Food Vendor(s) Information	X	X
Site Plan/ Map of Route or Parade	X	X
Off-Site Parking Permission <input type="checkbox"/> <input type="checkbox"/> <input type="checkbox"/> <input type="checkbox"/>	-	-
Liability Insurance	-	-

Staff Detail Service Requests	Detail Attached	Cost	Fees Waived
Public Works Department	-	-	-
Police Department	-	-	-
Fire Department	-	-	-

Other Services	Yes / No	Date
Boat Ramp Closure	N	-
Boat Trailer Lot Closure	N	-
Street Closures	N	-
Barricades/ Cones	N	-
Park Pavilion Booked	N	-
Emailed for town advertising	Y	
Submit Separate Detail Requests & Work Orders	N	-
Traffic Advisory Scheduled	N	-
Grill or Cooking Equipment Use <i>(if in-town business, not required)</i>	Y	
Fire Marshall Inspection	Y	

DEPARTMENTAL APPROVALS

Seaside
Bazaar

FIRE/EMS

Approved Denied Cost to Dept.: \$ _____

Approved with the following conditions: _____

Signature of Chief: _____ Date: 2/26/25

FIRE MARSHAL

Approved Denied Cost to Dept.: \$ _____

Approved with the following conditions: _____

Signature of Fire Marshal: Daniel Hooker Date: 2/27/25

POLICE

Approved Denied Cost to Dept.: \$ _____

Approved with the following conditions: _____

Signature of Chief: Jeff Du Date: 2/24/25

PUBLIC WORKS

Approved Denied Cost to Dept.: \$ _____

Approved with the following conditions: _____

Signature of Director: Steve Wargo Date: 2/28/25

BUILDING DIVISION

Approved Denied Cost to Dept.: \$ _____

Approved with the following conditions: _____

Signature of Building Official: Mark Date: 2-28-25

PLANNING & ZONING DIVISION

Approved Denied Cost to Dept.: \$ _____

Approved with the following conditions: _____

Signature of Director: Dean Date: 3/3/25

TOWN MANAGER

Approved Denied

Approved with the following conditions: _____

Total Depts. Event Cost: \$ _____

Signature of Town Manager: Michael Date: 3-3-25



Town of Ponce Inlet
Cultural Services Department
 4300 S. Atlantic Avenue
 Ponce Inlet, FL 32127
 386-322-6703

SPECIAL EVENT PERMIT APPLICATION

Pursuant to Chapter 51 of the Code of Ordinances

Permit #: _____
 Submittal Date: 2/4/25 JA
 FEE PAID: Waiver requested

APPLICATIONS MAY BE SUBMITTED UP TO 365 DAYS IN ADVANCE OF THE EVENT, BUT NO LESS THAN 28 DAYS PRIOR TO EVENT DATE, OR 60 DAYS PRIOR IF REQUESTING TOWN CO-SPONSORSHIP.

Please submit the following information with your application:

- A site plan of the event area(s) with all applicable information requested below.
- If the event is on town property, a certificate of insurance showing the town as additional insured in the amount of \$1,000,000 is required.

SECTION 1: EVENT INFORMATION

Event Name: <u>Seaside Spring Bazaar</u>	
Event Location: <u>Ponce Inlet Community Center (PICCT)</u>	
Date(s) of Event: <u>4-5-2025</u>	Event Hours: <u>10 am - 3 pm</u>
Brief Event Description: <u>This is a fundraising event put on by the Friends Group for the MSC. There will be vendors selling their wares + 2 food trucks</u>	
Estimated Attendance: <u>1000</u>	Repeat Event: <input checked="" type="radio"/> Yes <input type="radio"/> No

SECTION 2: APPLICANT INFORMATION

Business/ Organization Hosting Event: <u>Friends of the Marine Science Center</u>	
Authorized Head of Business/ Organization: <u>Mary Hoffman</u>	
Phone Number: <u>407 595-9539</u>	Email Address: <u>mhoffman2424@gmail.com</u>
Event Applicant/ Contact:	
Day-of Phone Number: <u>847 421-3539</u>	Email Address: <u>mindycash7@gmail.com</u>
Mailing Address: <u>4890 Sailfish Dr, Ponce Inlet</u>	

SECTION 3: ADDITIONAL INFORMATION

Please answer the questions below. If answering "Yes," indicate the location(s) on your site plan, providing any additional details on a separate sheet if needed.

Traffic Control Required? <input type="radio"/> Yes <input checked="" type="radio"/> No	Parade? <input type="radio"/> Yes <input checked="" type="radio"/> No *Provide a map and streets to be closed*
Portable Restrooms? <input type="radio"/> Yes <input checked="" type="radio"/> No	Private Security Firm? <input type="radio"/> Yes <input checked="" type="radio"/> No
Shuttle Transportation? <input type="radio"/> Yes <input checked="" type="radio"/> No	Name of Security Firm
Off-Site Parking Required? <input type="radio"/> Yes <input checked="" type="radio"/> No	

Provide written agreement with property owner(s) and number of spaces needed

Provide a site-plan showing the means of all vehicular (including shuttle) and pedestrian ingress & egress to and from the event.

SECTION 4: TEMPORARY USE - Additional Permits may be required.

Please answer the questions below. If answering "Yes," indicate the location(s) on your site plan, providing any additional details on a separate sheet if needed.

Barricades Required? <input type="radio"/> Yes <input checked="" type="radio"/> No	Traffic Cones Required? <input checked="" type="radio"/> Yes <input checked="" type="radio"/> No
Amplified Sound? ¹ <input type="radio"/> Yes <input checked="" type="radio"/> No	High-Intensity Lighting? ² <input type="radio"/> Yes <input checked="" type="radio"/> No *Provide specifications*
# of Tents (over 10'x10')? <input type="radio"/> 0	# Stages/ Structures? ³ <input type="radio"/> 0
Tent Size ³ (if over 10'x10')	Stage Dimensions:
	# of Signs/ Banners? ⁴ <input checked="" type="radio"/> 2 <input type="radio"/> 0
	Sign permit application submitted to Building Division? <input type="radio"/> Yes <input checked="" type="radio"/> N/A If yes, permit #:
How do you plan to collect and remove trash and litter during and after the event? <i>Organizers will dispose in on-site bins, dumpster</i>	
Food Prepared On-Site? ⁵ <input type="radio"/> Yes <input checked="" type="radio"/> No	
# of Mobile Food Vendors (MFV)? ⁶ <i>2</i>	# Parking Spaces Required for MFVs? *Include on your site plan
DBPR Food Service License # *Attach copy of License	DBPR Alcoholic Beverage License # ⁷ *Attach copy of License <i>NA</i>

Supplementary Regulations for Special Events:

- 1- See [Code of Ordinances Sec. 34-93](#) for sound limitations and [Code of Ordinances Sec. 34-94](#) for permit requirements to exceed maximum allowable noise level limits and restricted hours.
- 2- See [Code of Ordinances Sec. 34-99.1-5](#) for Town policy on nuisance lighting, requirements to reduce light trespass and glare. This section does not prohibit the temporary exterior lighting used for civic celebration and promotion associated with a permitted special event.
- 3- Tents larger than 10'x10' and stages require a fire inspection and building inspection in addition to a building permit
- 4- See [LUDC Sec. 3.30.6](#) and [Resolution 2011-03](#) for temporary sign regulations. To prevent signs from interfering with public utilities, contact Sunshine State One Call at 1-800-561-6720 prior to digging for sign installation.
- 5- [Code of Ordinances Sec. 46-3.a.4](#): Use of any portable cooking equipment is prohibited in all Town parks except in designated areas of Davies Lighthouse Park. Within designated areas, only propane and electric portable equipment is permitted – no charcoal.
- 6- [LUDC Sec. 3.34](#): Mobile Food vending is the sale of food, either prepared on location or pre-packaged, from a mobile food vending vehicle. Mobile food vendors shall comply with regulations from this section and shall be subject to an inspection pursuant to the NFPA and Florida Fire Prevention Code.
- 7- [Code of Ordinances Sec. 6-7.a](#): It is unlawful for any person to consume or possess any alcoholic beverages on public streets, sidewalks within the town, or on any town property or public park located in the town except as provided in the Code or as approved by Town Council.

I hereby state that the above information is true and accurate to the best of my knowledge. I further understand and agree to any and all conditions and costs of the required permits. I understand that the Town of Ponce Inlet assumes no liability for this event. I hereby agree to defend, hold harmless, and indemnify the Town, at the Town's option, from any and all demands, claims, suits, actions and legal proceedings brought against the Town in connection with this event, whether threatened or otherwise, to the full extent as permitted by the law of the State of Florida. This provision shall survive the term of this agreement and shall remain in full force and effect until the expiration of the time for the institution of any action at law or equity or administrative action against the Town under either federal law or the laws of Florida.

Melinda C Ash

Signature of Applicant

2-4-2025

Date Signed

STATE OF FLORIDA
COUNTY OF VOLUSIA

This document was sworn to (or affirmed) and subscribed before me by me of physical presence or online notarization, this *4th* day of *February*, 2025 he/she is personally known to me or has presented *FL/DL* as identification.

Notary stamp/ seal:

Heather M Lill



HEATHER M. LILL
Notary Public
State of Florida
Comm# HH207711
Expires 1/26/2026

STANDARD CONDITIONS FOR SPECIAL EVENT PERMITS

Per [Code of Ordinances Sec. 51-9](#).

Standards and conditions for issuance of permit. The special event review committee will review the special event permit application based upon the following standards and conditions:

- (a) The conduct of the event will not substantially interrupt the safe and orderly movement of other pedestrian or vehicular traffic in the vicinity of the event.
- (b) The conduct of the event will not require the diversion of so great a number of public safety personnel or equipment of the town to properly secure the event area and the areas contiguous thereto, as to prevent current level of public safety services from being furnished to other parts of the town.
- (c) The event shall not take place until inspections of the special event site have been conducted by the appropriate departments to determine whether this ordinance and any conditions of the special event permit have been met or satisfied.
- (d) The concentration of persons, animals and/or vehicles at the event will not unduly interfere with proper fire and/or police protection of, or ambulance service to, areas contiguous to the event area or other areas of the town.
- (e) The conduct of the special event is not reasonably likely to cause injury or intended to cause injury to persons or property, create an environment not compatible with a residential neighborhood if within or abutting a residential neighborhood, or to result in disorderly conduct as defined by town ordinance or state statutes, provided that the town may not deny a permit solely on the basis of the proposed content of speech or ideas of the group involved.
- (f) The conduct of the event shall not introduce extraordinary hazards to fire protection and/or life safety in the immediate or adjacent areas.
- (g) Adequate sanitation and other required health facilities are, or will be, made available in or adjacent to the event area. These include restrooms, trash receptacles, or anything normally required by the health department.
- (h) The conduct of the special event must be in accordance with the town's noise ordinance.
- (i) There are sufficient parking places on site and/or written approvals from off-site property owners where off-site parking is to occur, to accommodate the approximate number of automobiles expected to be driven to the special event.
- (j) Precautions will be taken to ensure protection of landscaping and irrigation systems.
- (k) The applicant has secured security personnel or police, fire/emergency medical services protection and public works services, if any, are required under this procedure. If applicant has secured police, fire/emergency medical services, or public works services from the town, (s)he must prepay the expenses thereof.
- (l) The applicant shall obtain public liability and property damage insurance, with the town named as an additionally insured party for any special event that is held on town property or that utilizes town facilities, in an amount approved by the town, as recommended by the town's insurance carrier. The applicant shall place on file with the town a certified insurance policy issued by a company authorized to do business in the state.
- (m) Application for a special event permit shall constitute an agreement by the applicant to pay for town personnel expenses and extraordinary services provided by the town, including any repairs, renovations and/or landscaping and turf restorations or replacement of town property which is necessitated by virtue of the special event.
- (n) Any temporary lighting will not adversely affect adjacent properties.
- (o) No applicant shall be granted a permit for an event that is to occur over a period longer than seven consecutive days.
- (p) No applicant shall be granted more than twelve special events permits in a single calendar year.

NOTE: The town may deny or revoke a permit for failure of the applicant to satisfy the applicable standards set forth in this chapter and the requirements of the permit, pursuant to [Code of Ordinances Sec. 51-10\(b\)](#).



S Peninsula Dr

4650
4668

S Peninsula Dr

Ponce Church

Ponce Inlet
Community Center

S Penins

4680 S Peninsula Dr
Ponce Inlet, FL 32127
4 min drive - home

Ron DeSantis, Governor



Melanie S. Griffin, Secretary



**STATE OF FLORIDA
DEPARTMENT OF BUSINESS AND PROFESSIONAL REGULATION**

DIVISION OF HOTELS AND RESTAURANTS

THE MOBILE FOOD DISP VEHICLE (2014) HEREIN IS LICENSED UNDER THE
PROVISIONS OF CHAPTER 509, FLORIDA STATUTES
VIN NUMBER: 1GBGP32K0S3310648 SELF SUFFICIENT

THE ICE QUEEN TRUCK LLC

THE ICE QUEEN TRUCK 3
655 ARNAU DRIVE
VIN 0648
NEW SMYRNA BEACH FL 32168

LICENSE NUMBER: MFD7450820

EXPIRATION DATE: APRIL 1, 2025

Always verify licenses online at MyFloridaLicense.com

ISSUED: 02/09/2024

Do not alter this document in any form.

This is your license. It is unlawful for anyone other than the licensee to use this document.



Ron DeSantis, Governor



Melanie S. Griffin, Secretary



**STATE OF FLORIDA
DEPARTMENT OF BUSINESS AND PROFESSIONAL REGULATION**

DIVISION OF HOTELS AND RESTAURANTS

THE MOBILE FOOD DISP VEHICLE (2014) HEREIN IS LICENSED UNDER THE
PROVISIONS OF CHAPTER 509, FLORIDA STATUTES
VIN NUMBER: 4c9be1215mf502780 SELF SUFFICIENT

BEACHIE BUM LLC

BEACHIE BUM
4170 US 1
EDGEWATER FL 32141

LICENSE NUMBER: MFD7451047

EXPIRATION DATE: APRIL 1, 2025

Always verify licenses online at MyFloridaLicense.com

ISSUED: 01/11/2025

Do not alter this document in any form.

This is your license. It is unlawful for anyone other than the licensee to use this document.





Meeting Date: 3/20/2025

Agenda Item: 8-B

Report to Town Council

Topic: Town of Ponce Inlet Podcast Name.

Summary: Staff is seeking input from the Town Council on naming the Town of Ponce Inlet podcast. After petitioning name suggestions from social media, the top five selections were identified. Please see the attached staff report for more information.

Suggested motion: As determined by Council.

Requested by: Ms. Hugler, Fire Department Office Manager/PIO

Approved by: Mr. Disher, Town Manager



MEMORANDUM

TOWN OF PONCE INLET, FIRE DEPARTMENT

The Town of Ponce Inlet staff shall be professional, caring, and fair in delivering community excellence while ensuring Ponce Inlet residents obtain the greatest value for their tax dollar.

To: Michael E. Disher, AICP, Town Manager
From: Becky Hugler, Public Information Officer
Date: March 12, 2025
Subject: Town of Ponce Inlet Podcast Name

MEETING DATE: March 20, 2025

The purpose of this memorandum is to seek input from the Town Council on naming our Town of Ponce Inlet podcast.

Why a Podcast?

A podcast offers a modern, flexible way to engage with our community by providing easily accessible information in an audio format. It allows residents to stay informed on town updates, events, and important issues at their convenience, whether at home, commuting, or on the go.

Episode Topic Ideas:

- Town news, events, and community updates.
- Interviews with town officials, community leaders, and residents.
- Environmental initiatives and local conservation efforts.
- Emergency preparedness tips (hurricanes, wildfires, safety measures).
- Behind-the-scenes insights into town departments and projects.

Episode Length: 20 minutes per episode

Frequency: Monthly or bi-weekly releases

After soliciting name suggestions via social media, 17 potential names were collected:

- The Ponce Inlet Show
- Ponce 411
- Salute Ponce Inlet
- The Ponce Lightcast
- Surf, Signal & Stories: The Ponce Inlet Podcast

- The Guiding Light: The Ponce Inlet Podcast
- Ponce Perspectives
- Helloooooo Ponce Inlet
- All Things Ponce
- PIPOD
- Poncecast
- Ponce Upon a Time
- Perfectly Ponce
- The Ponce Post
- The Ponce Connection
- Town Talk: Ponce Inlet
- Inside Ponce Inlet
- The Ponce Inlet Update

Following a vote on social media, the top five selections are:

1. Ponce Lightcast
2. Poncecast
3. Ponce Insider
4. Perfectly Ponce
5. Ponce 411

Staff is requesting the Town Council select the official podcast name. While the community vote identified the top five options, the Council may also choose to select a name from the entire list of submissions.



Meeting Date: 3/20/2025

Agenda Item: 11-A

Report to Town Council

Topic: First reading of Ordinance 2025-02, Amending the Land Acquisition Fund to allow the expenditure of funds for purposes other than public land acquisition and public facilities.

Summary: The attached ordinance has been drafted in response to the Town Council's directive during the November 21, 2024 Town Council meeting to amend the limitations on how monies from the Land Acquisition Fund can be used. The Essential Services Advisory Board (ESAB) reviewed additional potential uses during its March 6, 2025 meeting.

Suggested motion: Staff recommends approval of proposed Ordinance 2025-02, amending Section 2-322 of the Code of Ordinances to allow expenditures from the Land Acquisition Fund for purposes other than public land acquisition and public facilities, as recommended by the ESAB.

Requested by: Mr. Disher, Town Manager

Approved by: Mr. Disher, Town Manager



MEMORANDUM
OFFICE OF THE TOWN MANAGER

The Town of Ponce Inlet staff shall be professional, caring and fair in delivering community excellence while ensuring Ponce Inlet citizens obtain the greatest value for their tax dollar.

To: Town Council
From: Michael E. Disher, AICP, Town Manager
Date: March 12, 2025
Subject: Ordinance 2025-02 – First Reading - Amending the Land Acquisition Fund to allow the expenditure of funds for purposes other than public land acquisition and public facilities

MEETING DATE: March 20, 2025

1 **Introduction**

2 At its meeting on November 21, 2024, the Town Council discussed amending the limitations on
3 how monies from the Land Acquisition Fund can be used. Per Section 2-322 of the Code of
4 Ordinances, these non-ad valorem revenues are used primarily to acquire real estate and construct
5 public facilities. Their only other use is in the event of a natural disaster or financial emergency,
6 upon request by the Town Manager to the Town Council and approval by a four-fifths vote. The
7 idea to amend the limitations was in response to the purchase and financing of a new 75’ Quint
8 fire apparatus; specifically, whether it could be paid for with Land Acquisition Fund monies rather
9 than property taxes. After discussion, the Council members indicated their preference to allow
10 limited use of these funds to pay for vehicles on a case-by-case basis, subject to Council approval.
11 The Council directed staff to draft an ordinance for this purpose, but to first provide it to the
12 Essential Services Advisory Board (ESAB) for review and recommendation (see meeting minutes,
13 **Exhibit 1**). For additional background information, please see Staff’s report dated November 12,
14 2024 (**Exhibit 2**).

15
16 **Amendment Proposal**

17 Removing the limitation on expenditures only in the event of natural disaster or financial
18 emergency would allow the funds to be used for any other purpose, subject to a four-fifths vote of
19 the Town Council. This proposed change is shown below.

20
21 “All revenue generated and collected by the town from franchise fees pursuant to [section 62-41](#) for
22 the collection of garbage and the public service tax pursuant to [section 72-101](#) et seq. on the sale
23 of electricity, metered natural gas, liquefied petroleum and manufactured gas shall be deposited

24 into the town public land acquisition and facility fund, and shall be expended from that fund only
25 for the purposes of acquiring real estate, construction of public facilities and payment of
26 administrative, engineering and legal expenses related to those tasks. ~~In the event of a natural~~
27 ~~disaster or financial emergency,~~ The town manager may request the town council to permit the
28 expenditure of funds from the town public land acquisition and facility fund for other purposes and
29 the town council may grant this request only by a four-fifths vote of the members present. The town
30 manager is authorized to make expenditures from this fund within the parameters of this section.”

31
32 **Discussion**
33 The ESAB reviewed additional potential uses of the Land Acquisition Fund, such as setting aside
34 a certain amount each year for various funds (e.g. Disaster Recovery Fund, Capital Fire Equipment
35 Fund, etc.), paying off existing vehicle leases; or funding future significant vehicle/equipment
36 purchases, like the new back-hoe needed for Public Works.

37
38 The ESAB was also provided information about the need to use the fund for future short- and long-
39 term resilience improvement projects, as outlined in the 2024 Watershed Master Plan¹, such as the
40 acquisition of flood-prone properties and reconstruction of low-lying Town-owned buildings
41 above the flood plain (e.g. the fire station).

42
43 Following discussion, the ESAB recommended approval of the amendment to the Land
44 Acquisition Fund as proposed. The ESAB further recommended transferring a portion of the
45 revenue from the Land Acquisition Fund each year to build up the Disaster Recovery Fund to a
46 sufficient amount for future hurricanes, and establishing a minimum “floor” funding level for that
47 fund. Doing so would be handled through a separate resolution, similar to the one that created the
48 Disaster Recovery Fund itself², rather than codification.

49
50 **Recommendation**
51 To **approve** Ordinance 2025-02, amending Section 2-322 of the Code of Ordinances to allow
52 expenditures from the Land Acquisition Fund for purposes other than public land acquisition and
53 public facilities, as recommended by the ESAB. If the Council also wishes to use the Land
54 Acquisition Fund to support the Disaster Recovery Fund, staff will prepare a separate resolution
55 in conjunction with second reading of the subject ordinance. If approved, the ordinance and
56 resolution will be used in the preparation of the FY 25/26 budget, effective October 1, 2025.

Exhibits

- 1. Excerpt from Town Council meeting minutes, 11-21-24
- 2. Staff report dated 11-12-24

¹ See <https://www.ponce-inlet.org/DocumentCenter/View/4478/Watershed-Master-Plan>
² Res. 2024-13

EXHIBIT 1

Excerpt from November 21, 2024 Town Council meeting minutes

14. NEW BUSINESS:

A. Discussion – Amending the Land Acquisition Fund to allow vehicle and equipment purchases. – Mr. Disher stated that during recent budget hearings, the Town Council directed staff to research amending the Land Acquisition Fund to allow vehicle and equipment purchases. He elaborated on how the Fund was established and explained how revenue is collected from franchise fees, not from property taxes. The Fund was adopted by ordinance, which currently limits how monies from the Fund can be used. With the recent consideration to purchase the 75' Quint Fire Apparatus, discussions took place regarding whether it could be financed through the Land Acquisition Fund. Mr. Disher referred to attachments in the staff report regarding the Land Acquisition Fund including major expenses, year-by-year revenues, trendline projections, and the reserves projection. He explained the potential impact to Fund reserves by funding the purchase of the fire truck through the Land Acquisition Fund, should Council decide to move forward with the amendments. He requested direction from the Council on the potential use of the fund, and stated staff will draft an ordinance that will be used in preparation of the FY 25/26 budget effective October 1, 2025. Mayor Paritsky recommended presenting the suggestions to the Essential Services Advisory Board. Councilmember White expressed his interest in utilizing the Land Acquisition Fund but stated he would like it to remain restricted. He elaborated on the idea of utilizing the Fund for some items which would be presented to and approved by Council. The Council addressed future planning and appropriation requests to ensure the recommended drainage improvements from the Watershed Master Plan will still be adhered to.

Mayor Paritsky opened public participation – Mr. Steve Field, 6 Mar Azul, expressed his interest for a percentage of funds to be set aside for reserves. Mayor Paritsky closed public participation.

Council provided direction to staff on amendments to the Land Acquisition Fund and for the amendments to be reviewed by the Essential Services Advisory Board.

EXHIBIT 2



Meeting Date: 11/21/2024

Agenda Item: 14-A

Report to Town Council

Topic: Discussion – Amending the Land Acquisition Fund to allow vehicle and equipment purchases.

Summary: Please see attached staff report and supporting documents.

Suggested motion: At Council's discretion.

Requested by: Mr. Disher, Town Manager

Approved by: Mr. Disher, Town Manager



MEMORANDUM
OFFICE OF THE TOWN MANAGER

The Town of Ponce Inlet staff shall be professional, caring and fair in delivering community excellence while ensuring Ponce Inlet citizens obtain the greatest value for their tax dollar.

To: Town Council
 From: Michael E. Disher, AICP, Town Manager
 Date: November 12, 2024
 Subject: Discussion – Amending the Land Acquisition Fund to allow vehicle and equipment purchases

MEETING DATE: November 21, 2024

1 **Introduction**

2 During its meetings on September 19, 2024 and October 17, 2024, the Town Council discussed
 3 amending the limitations on how monies from the Land Acquisition Fund can be used. Currently,
 4 these non-ad valorem revenues can only be used to acquire real estate and construct public
 5 facilities. The question was raised in response to the purchase and financing of a new 75’ Quint
 6 fire apparatus; specifically, whether the Land Acquisition Fund monies could help pay for it rather
 7 than with property taxes. This purpose of this memo is to provide information and potential options
 8 for discussion should the Council decide to make changes to the Land Acquisition Fund.

9
 10 **Background**

11 The L.A. Fund was established on April 16, 2003 via Ordinance 2003-05, creating Section 2-322
 12 of the Code of Ordinances. The section reads:

13
 14 “All revenue generated and collected by the town from franchise fees pursuant to [section 62-](#)
 15 [41](#) for the collection of garbage and the public service tax pursuant to [section 72-101](#) et seq. on
 16 the sale of electricity, metered natural gas, liquefied petroleum and manufactured gas shall be
 17 deposited into the town public land acquisition and facility fund, and shall be expended from
 18 that fund only for the purposes of acquiring real estate, construction of public facilities and
 19 payment of administrative, engineering and legal expenses related to those tasks. In the event
 20 of a natural disaster or financial emergency, the town manager may request the town council
 21 to permit the expenditure of funds from the town public land acquisition and facility fund for
 22 other purposes and the town council may grant this request only by a four-fifths vote of the
 23 members present. The town manager is authorized to make expenditures from this fund within
 24 the parameters of this section.”
 25

26 The 10% franchise fee and public utility service tax had been enacted two months prior, via
27 Ordinance 02-37. The Council meeting minutes from the time note that these fees and taxes were
28 necessary to create an alternate source of revenue besides ad valorem taxes, for funding the
29 construction of the new Town Hall facility and acquiring properties for conservation, recreation,
30 and historic preservation. The new fees and taxes were expected to bring in between \$270,000 to
31 \$300,000 per year.

32
33 Section 2-322 was amended on September 17, 2020 via Ordinance 2020-08 to require a
34 supermajority four-fifths vote to amend or withdraw any portion of this section or its subsections.
35 If the Council wishes to change how the L.A. Fund monies are used, such an amendment must be
36 adopted by ordinance with at least a four-fifths vote.

37
38 **Discussion**
39 To date, the Fund has been used to pay for \$7,748,896 worth of purchases of property and
40 construction of new facilities. This fiscal year, \$643,557 has been budgeted to pay the last
41 installment of the 20-year Town Hall loan and to replace Public Works Building “B.” A list of
42 major purchases over time is provided on **Attachment 1**.

43
44 The historic and projected Fund revenues are shown on **Attachment 2**. A trendline analysis has
45 been applied to project Fund revenues out to the year FY 32/33. The Fund’s recent and projected
46 reserves are shown on **Attachment 3**. Together, they show that there is sufficient revenue available
47 should the Council decide to use this Fund to pay for the new Quint fire truck over its 7-year loan
48 period. At the start of Fiscal Year 25/26, the Fund is projected to have a reserve balance of
49 \$596,117. Even after making the 7 annual payments of \$209,839, the Fund is projected to have a
50 reserve balance of \$3,226,963 by the start of FY 32/33.

51
52 **Questions**
53 Revising the built-in restrictions of this fund raises questions that should be addressed before
54 amending the ordinance itself. These include, but may not be limited to, the following:

- 55
56 1. Should the change be permanent or limited to one-time purchases (e.g., the fire apparatus)?
57 2. If permanent, what other uses for this money are acceptable? Ideas may include:
58 ○ Setting aside a certain amount or percentage each year for the Disaster Recovery
59 Fund, Capital Facility Maintenance Fund, and/or Capital Fire Equipment Fund;
60 ○ Paying off existing vehicle leases; or
61 ○ Funding future significant vehicle/equipment purchases, like the new back-hoe
62 needed for Public Works.

63
64 Regardless of any changes, the Fund will need to play a significant role in funding future
65 improvements related to the Town’s short- and long-term resilience, as outlined in the recently
66 completed Watershed Master Plan. These will include the acquisition of repetitive-loss, flood-
67 prone properties for additional stormwater retention; expanding the capacity of the existing

68 stormwater drainage system; and reconstruction of low-lying Town-owned buildings above the
69 flood plain (e.g. the fire station). The Resilient Florida grant program will not pay for the
70 architectural/engineering design for such projects, although it will pay up to 50% of the
71 construction. However, such grants are always in the form of a reimbursement, meaning the Town
72 would need to cover the initial costs up front.

73

74 **Conclusion**

75 Staff requests direction from the Town Council on the potential use of this fund for significant
76 purchases once the Town Hall loan is paid off. Based on this direction, Staff will draft an ordinance
77 for an upcoming meeting for approval or further discussion. Any changes authorized by this
78 ordinance will be used in preparation of the FY 25/26 budget, effective October 1, 2025.

ATTACHMENT 1

Major Expenses for Land Acquisition (302) Fund		
Purchase	Amount	Fiscal Year(s)
Town Hall	\$6,174,910.82	FY 05/06 through FY 24/25
Pay off remainder of 15-year loan for purchase of Diocese property	403,963.00	FY 08/09
Purchase property at S. Peninsula (NW corner of Public Works)	16,532.00	FY 09/10
Purchase vacant land - 121 Beach Street (later sold)	235,364.00	FY 11/12
Purchase vacant land - NE corner of S. Peninsula & Beach Street (Public Works parking expansion site)	255,000.00	FY 14/15
Pollard Park redevelopment	700,749.00	FY 17/18 through FY 19/20
Davie's Lighthouse Park enhancement	110,608.00	FY 18/19
Town Hall remodel (new conference room and Clerks office)	146,636.81	FY 22/23
Pollard Park pickleball court shade structures	73,690.00	FY 22/23
Building B reconstruction (estimated)	275,000.00	FY 24/25
Total	\$8,392,453.63	

Land Acquisition Fund Year-by-Year Revenues with Trendline Projections

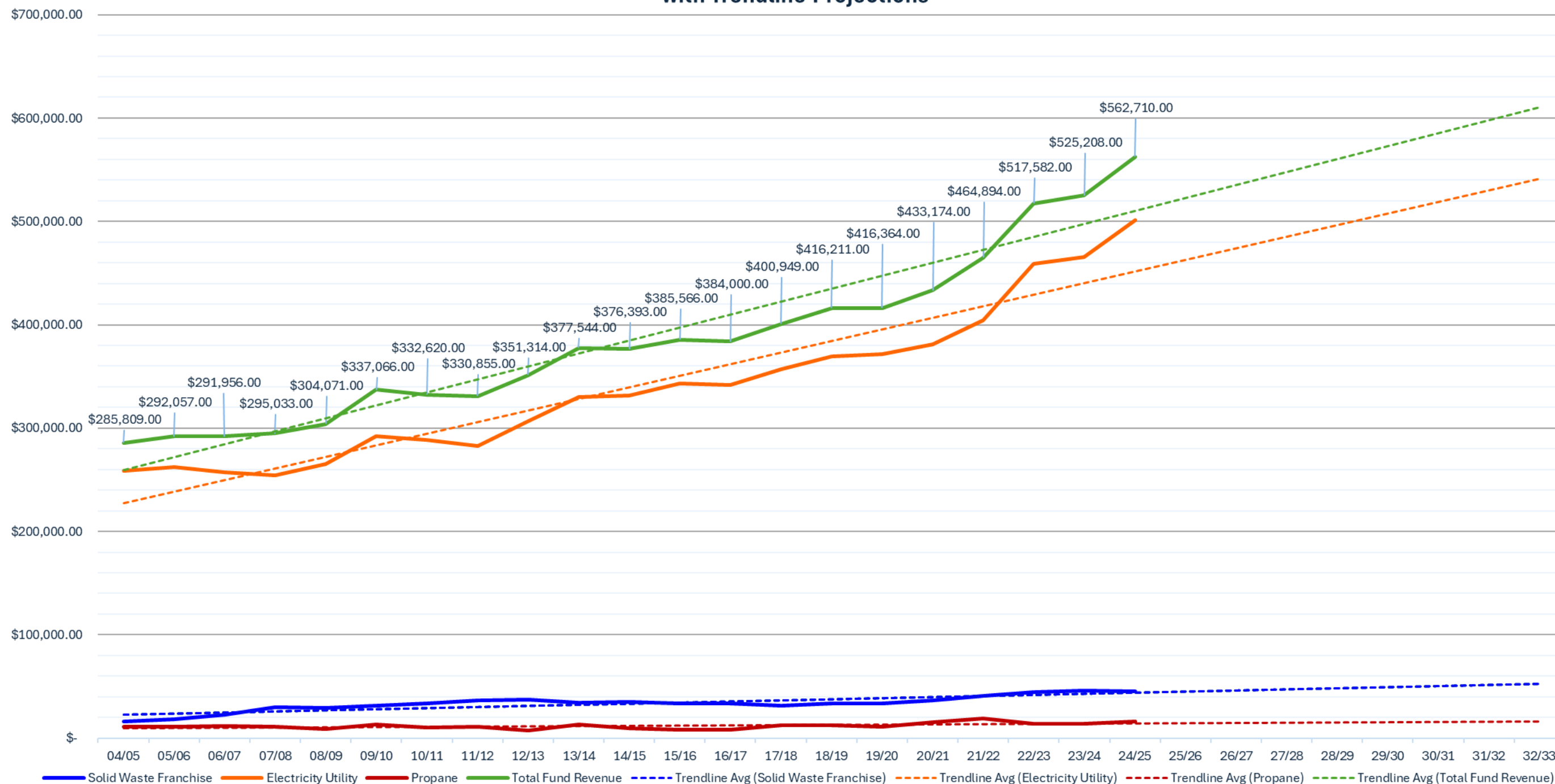

ATTACHMENT 3

302 Fund Reserves Projection

FY 23/24 Beginning Reserves	439,546.00
FY 23/24 Revenues	525,208.00
FY 23/24 Town Hall Payment	(328,400.00)
	<hr/>
FY 24/25 Beginning Reserves	636,354.00
FY 24/25 Estimated Revenue	562,710.00
FY 24/25 Town Hall Payment	(327,947.00)
FY 24/25 Building B	(275,000.00)
	<hr/>
FY 25/26 Estimated Reserves	596,117.00
FY 25/26 Estimated Revenues	568,337.00
FY 25/26 - 1st Fire Truck Payment	(209,839.00)
	<hr/>
FY 26/27 Estimated Reserves	954,615.00
FY 26/27 Estimated Revenues	574,020.00
FY 26/27 - 2nd Fire Truck Payment	(209,839.00)
	<hr/>
FY 27/28 Estimated Reserves	1,318,796.00
FY 27/28 Estimated Revenues	579,761.00
FY 27/28 - 3rd Fire Truck Payment	(209,839.00)
	<hr/>
FY 28/29 Estimated Reserves	1,688,718.00
FY 28/29 Estimated Revenues	585,558.00
FY 28/29 - 4th Fire Truck Payment	(209,839.00)
	<hr/>
FY 29/30 Estimated Reserves	2,064,437.00
FY 29/30 Estimated Revenues	591,414.00
FY 29/30 - 5th Fire Truck Payment	(209,839.00)
	<hr/>
FY 30/31 Estimated Reserves	2,446,012.00
FY 30/31 Estimated Revenues	597,328.00
FY 30/31 - 6th Fire Truck Payment	(209,839.00)
	<hr/>
FY31/32 Estimated Reserves	2,833,501.00
FY 31/32 Estimated Revenues	603,301.00
FY 31/32 - 7th and Final Fire Truck Payment	(209,839.00)
	<hr/>
FY 32/33 Estimated Reserves	3,226,963.00

Note: FY 25/26 - FY 31/32 estimated revenues were projected to increase 1% each year.

This projection appeared to be relatively close to the trendline projection.

ORDINANCE 2025-02

AN ORDINANCE OF THE TOWN COUNCIL OF THE TOWN OF PONCE INLET, VOLUSIA COUNTY, FLORIDA AMENDING ARTICLE VII, CHAPTER 2, SECTION 2-322 OF THE TOWN CODE OF ORDINANCES TO AUTHORIZE THE EXPENDITURE OF FUNDS ALLOCATED UNDER SECTION 2-322 FOR PURPOSES OTHER THAN PUBLIC LAND ACQUISITION AND PUBLIC FACILITIES, SUBJECT TO A FOUR-FIFTHS (4/5) VOTE OF THE TOWN COUNCIL; PROVIDING FOR CONFLICTING ORDINANCES; CODIFICATION; SEVERABILITY; AND FOR AN EFFECTIVE DATE.

WHEREAS, The Land Acquisition and Facility Fund was established on April 16, 2003 via Ordinance 2003-05, creating Section 2-322 of the Town of Ponce Inlet Code of Ordinances.

WHEREAS, Section 2-322(b) of the Code of Ordinances allows the expenditure of funds for purposes other than public land acquisition and public facilities only in the event of a natural disaster or financial emergency, subject to a four-fifths (4/5) vote of the Town Council; and

WHEREAS, the Town Council finds that the provisions of Section 2-322 serve a valid and important public purpose by providing a reliable, alternate source of revenue besides ad valorem taxes; and

WHEREAS, the Town Council finds that from time to time circumstances other than a natural disaster or financial emergency may arise when it is appropriate to allow the expenditure of said funds for purposes other than public land acquisition and public facilities; and that removing such restriction serves the public interest; and

WHEREAS, this ordinance is enacted pursuant to the authority given to municipalities under FLA. STAT. § 166.041(6) and under the general home rule and police powers of the Town of Ponce Inlet.

NOTE: Underlined words constitute additions to the Town of Ponce Inlet Code of Ordinances, ~~strikethrough~~ constitutes deletions from the current Code of Ordinances, and asterisks (***) indicate an omission from the existing text which is intended to remain unchanged.

NOW, THEREFORE, BE IT ENACTED BY THE TOWN COUNCIL OF THE TOWN OF PONCE INLET, VOLUSIA COUNTY, FLORIDA:

SECTION 1. Legislative Findings and Intent. The findings set forth in the recitals above are hereby adopted as legislative findings pertaining to this ordinance as if fully set forth herein.

SECTION 2. Chapter 2, Article VII, Section 2-322(b) of the Code of Ordinances of the Town of Ponce Inlet is hereby amended as follows:

“All revenue generated and collected by the town from franchise fees pursuant to [section 62-41](#) for the collection of garbage and the public service tax pursuant to [section 72-101](#) et seq. on the sale of electricity, metered natural gas, liquefied petroleum and manufactured gas shall be deposited into the town public land acquisition and facility fund, and shall be expended from that fund only for the purposes of acquiring real estate, construction of public facilities and payment of administrative, engineering and legal expenses related to those tasks. ~~In the event of a natural disaster or financial emergency,~~ The town manager may request the town council to permit the expenditure of funds from the town public land acquisition and facility fund for other purposes and the town council may grant this request only by a four-fifths vote of the members present. The town manager is authorized to make expenditures from this fund within the parameters of this section.”

SECTION 3. Conflicts. In any case where a provision of this Ordinance is found to be in conflict with a provision of any other ordinance of this Town, this Ordinance shall prevail.

SECTION 4. Codification. It is the intent of the Town Council of the Town of Ponce Inlet that the provisions of this Ordinance shall be codified. The codifier is granted broad and liberal authority in codifying the provisions of this Ordinance.

SECTION 5. Severability. If any section, sentence, phrase, word or portion of this Ordinance is determined to be invalid, unlawful or unconstitutional, said determination shall not be held to invalidate or impair the validity, force or effect of any other section, sentence, phrase, word or portion of this Ordinance not otherwise determined to be invalid, unlawful or unconstitutional.

SECTION 6. Effective Date. This Ordinance shall become effective immediately upon its passage and adoption.

It was moved by _____ and seconded by _____ that said Ordinance be passed on first reading. A roll call vote of the Town Council on said motion resulted as follows:

Mayor Paritsky, Seat #1	_____
Councilmember Milano, Seat #2	_____
Councilmember White, Seat #3	_____
Councilmember Villanella, Seat #4	_____
Vice-Mayor Smith, Seat #5	_____

Approved on first reading this ___ day of _____ 2025.

It was moved by _____ and seconded by _____ that said Ordinance be passed on second reading. A roll call vote of the Town Council on said motion resulted as follows:

Mayor Paritsky, Seat #1 _____

Councilmember Milano, Seat #2 _____

Councilmember White, Seat #3 _____

Councilmember Villanella, Seat #4 _____

Vice-Mayor Smith, Seat #5 _____

Approved and adopted on second reading this ____ day of _____ 2025.

Town of Ponce Inlet, Florida:

Lois A. Paritsky, Mayor

ATTEST:

Kim Cherbano, CMC
Town Clerk



Meeting Date: 3/20/2025

Agenda Item: 11-B

Report to Town Council

Topic: Resolution 2025-02 – Extending the Sunset Date of the Public Safety Director *Pro Tem* position.

Summary: Please see attached staff report and supporting documentation.

Suggested motion: To approve Resolution 2025-02 as presented.

Requested by: Mr. Disher, Town Manager

Approved by: Mr. Disher, Town Manager



MEMORANDUM

TOWN OF PONCE INLET – OFFICE OF THE TOWN MANAGER

The Town of Ponce Inlet staff shall be professional, caring and fair in delivering community excellence while ensuring Ponce Inlet citizens obtain the greatest value for their tax dollar.

To: Town Council
From: Michael E. Disher, AICP, Town Manager
Date: March 11, 2025
Subject: Resolution 2025-02, Extending the Sunset Date of the Public Safety Director *Pro Tem* position

MEETING DATE: March 20, 2025

The position of Public Safety Director *Pro Tem* has been in effect¹ since October 23, 2022. First created to assist the Interim Town Manager and new Town Manager during the initial transition period, the position was later extended² for two more years until October 20, 2025.

Resolution 2022-15 specifically appointed Fire Chief Dan Scales to this position. Chief Scales is uniquely qualified to serve in this capacity given his expertise and history with the Town. Chief Scales is the most senior department head, having served in his role since 2005. He is also the Town's Emergency Management Director and has successfully guided the Town's emergency response through numerous hurricane events. In addition to these roles, Chief Scales has also served the Town as part-time IT Director and Interim Public Works Manager. He has demonstrated his ability to oversee and coordinate the work from the departments of Fire, Police, Public Works, and Information Technology. In the time since first being appointed as Interim Town Manager, I have found his assistance invaluable.

Chief Scales is currently in the DROP program and had initially expected to retire by the time the current extension expired. Recent changes to the DROP program now allow him to serve an additional two years if desired. He is willing and able to remain in his current assignment until that time. I therefore request that the Town Council approve Resolution 2025-02, extending the sunset date of the Public Safety Director *Pro Tem* position for two more years until October 20, 2027.

¹ Res. 2022-15

² Res. 2023-14



MEMORANDUM
Office of the Public Safety Director

The Town of Ponce Inlet staff shall be professional, caring and fair in delivering community excellence while ensuring Ponce Inlet citizens obtain the greatest value for their tax dollar.

To: Michael E. Disher, AICP, Town Manager
From: Dan Scales, CFO, Public Safety Director, Fire Chief
Date: March 12, 2025
Subject: Continuation as Public Safety Director

Town Council Meeting Date: March 20, 2025

1 Serving as Public Safety Director for Ponce Inlet has been one of the most fulfilling experiences
2 of my career. Together, we’ve made significant strides in improving emergency services,
3 strengthening our public safety infrastructure, and ensuring that our town remains a safe and well-
4 prepared community.

5 From enhancing fire and EMS services—including our full-service ALS patient transport—to
6 securing vital funding for public infrastructure and modernizing our police fleet, every effort has
7 been focused on the well-being of our residents. Our fire department is on track for accreditation
8 next fiscal year, we’ve improved our emergency preparedness, and we continue to build strong
9 partnerships at every level.

10 Beyond the projects and policies, what truly makes this role meaningful is the opportunity to serve
11 this community and support the dedicated professionals who protect it. Mentoring new department
12 heads, working alongside staff, and drawing from our town’s history to guide future decisions are
13 responsibilities I take to heart.

14 I am eager to continue this important work, leading with dedication, innovation, and a steadfast
15 commitment to public safety. Thank you for your ongoing support and trust. I look forward to
16 continuing to serve Ponce Inlet.

RESOLUTION NO. 2025-02

A RESOLUTION OF THE TOWN COUNCIL OF THE TOWN OF PONCE INLET, FLORIDA, EXTENDING THE SUNSET DATE OF THE PUBLIC SAFETY DIRECTOR PRO TEM, AS ESTABLISHED BY RESOLUTION 2022-15 AND EXTENDED BY RESOLUTION 2023-14; PROVIDING FOR CONFLICTING RESOLUTIONS; PROVIDING FOR SEVERABILITY; AND PROVIDING AN EFFECTIVE DATE.

WHEREAS, the Town of Ponce Inlet accepted the resignation of its previous Town Manager, effective October 22, 2022; and

WHEREAS, on September 15, 2022, the Town Council adopted Resolution 2022-15, designating an Interim Town Manager and creating the temporary position of “Public Safety Director Pro Tem” to assist the Interim Town Manager and new Town Manager during the initial transition period; and

WHEREAS, on September 21, 2023, the Town Council adopted Resolution 2023-14 to extend the sunset date of the Public Safety Director Pro Tem position to October 20, 2025.

WHEREAS, the Public Safety Director Pro Tem position has proven to be a highly successful model for providing coordination and management assistance in the time since its creation; and

WHEREAS, the Town Council now desires to extend the sunset date of the Public Safety Director Pro Tem position.

NOW, THEREFORE, BE IT RESOLVED BY THE TOWN COUNCIL OF THE TOWN OF PONCE INLET, AS FOLLOWS:

SECTION 1. Findings. The above recitals are true and correct and incorporated herein by this reference.

SECTION 2. Public Safety Director Pro Tem. The Town Council of the Town of Ponce Inlet hereby retains Daniel Scales as Public Safety Director Pro Tem, in addition to his normal duties for the Town. The Public Safety Director Pro Tem shall report to the Town Manager. The Public Safety Director Pro Tem shall provide management oversight, coordination, and be responsible for the following departments:

1. Police.
2. Fire.
3. Public Works.
4. Information Technology.

SECTION 3. Appointment Sunsetting. The appointment of the Public Safety Director

46 Pro Tem as provided by Resolution 2022-15 and extended by Resolution 2023-14 shall be
47 extended again to October 20, 2027.

48
49 **SECTION 4. Conflicting Resolutions.** All resolutions in conflict herewith are hereby
50 repealed to the extent of such conflict.

51
52 **SECTION 5. Severability.** If any section, sentence, phrase, word or portion of this
53 Resolution is determined to be invalid, unlawful or unconstitutional, said determination shall not
54 be held to invalidate or impair the validity, force or effect of any other section, sentence, phrase,
55 word or portion of this Resolution not otherwise determined to be invalid, unlawful or
56 unconstitutional.

57
58 **SECTION 6. Effective Date.** This Resolution shall become effective immediately upon
59 its passage and adoption.

60
61 It was moved by Councilmember _____ and seconded by Councilmember
62 _____ that said Resolution be passed. A roll call vote of the Town Council on
63 said motion resulted as follows:

- 64
- 65 Mayor Paritsky, Seat #1 _____
- 66 Councilmember Milano, Seat #2 _____
- 67 Councilmember White, Seat #3 _____
- 68 Councilmember Villanella, Seat #4 _____
- 69 Vice-Mayor Smith, Seat #5 _____
- 70

71 Passed this 20th day of March 2025.

Town of Ponce Inlet, Florida

72
73
74
75
76 _____
Lois A. Paritsky, Mayor

77 ATTEST:

78
79
80 _____
81 Kim Cherbano, Town Clerk



Meeting Date: 3/20/2025

Agenda Item: 13-A

Report to Town Council

Topic: Approval of Florida Power & Light (FPL) Agreement Designating the Town's Community Center as a Staging Location.

Summary: Staff is seeking approval for an agreement with Florida Power & Light (FPL) that designates the Ponce Inlet Community Center (4670 South Peninsula Drive) as a temporary staging area for utility restoration operations during natural disasters and emergency events. Please see the attached staff report and supporting documentation for more information.

Suggested motion: Staff recommends the Town Council approve the Staging Area Agreement with Florida Power & Light (FPL) and authorize the Town Manager to execute the agreement.

Requested by: Chief Scales, Public Safety Director

Approved by: Mr. Disher, Town Manager



MEMORANDUM
Office of the Public Safety Director

The Town of Ponce Inlet staff shall be professional, caring and fair in delivering community excellence while ensuring Ponce Inlet citizens obtain the greatest value for their tax dollar.

To: Michael E. Disher, AICP, Town Manager
From: Dan Scales, CFO, Public Safety Director, Fire Chief
Date: March 6, 2025
Subject: Approval of FPL Agreement Designating the Town’s Community Center (4670 South Peninsula Drive) as a Staging Location

Meeting Date: March 20, 2025

1 **PURPOSE**

2 To seek Town Council approval for an agreement with Florida Power & Light (FPL) that
3 designates the Ponce Inlet Community Center as a temporary staging area for utility restoration
4 operations during natural disasters and emergency events.

5 **BACKGROUND**

6 In the aftermath of hurricanes and other major emergencies, FPL requires strategically located
7 staging areas to support power restoration efforts. These sites serve as operational bases where
8 personnel, equipment, and materials can be mobilized quickly to expedite the restoration of
9 electrical services.

10 The Town of Ponce Inlet has historically faced prolonged power outages following severe
11 weather events, highlighting the need for an effective emergency response strategy. Establishing
12 a designated staging area at the Community Center (4670 S. Peninsula Dr.) ensures that
13 restoration crews have immediate access to a secure and centralized location for response
14 operations.

15 **AGREEMENT TERMS**

16 The proposed **Staging Area Agreement** provides FPL with temporary, non-exclusive use of the
17 Community Center property under the following conditions:

- 18 • **Activation Upon Request:** Use of the site must be pre-approved by the Town’s Public
19 Safety Director when an emergency declaration is in effect.
- 20 • **24/7 Access:** Once activated, FPL personnel will have continuous access for the duration
21 of the restoration efforts.
- 22 • **Site Responsibilities:**

- 23 ○ FPL is responsible for securing the site, providing necessary lighting, signage, and
24 fencing to restrict public access.
- 25 ○ Any necessary site improvements (e.g., temporary sanitation, fuel stations, office
26 trailers) will be funded by FPL.
- 27 ○ Within **10 days of vacating the site**, FPL must restore the property to its pre-use
28 condition at its own expense.
- 29 • **Liability & Insurance:**
- 30 ○ FPL indemnifies the Town against third-party claims arising from its use of the
31 site.
- 32 ○ The Town is not liable for damage to FPL equipment or vehicles.
- 33 ○ FPL is self-insured with a liability program covering up to **\$3 million per**
34 **occurrence**.
- 35 • **Agreement Term:**
- 36 ○ The agreement is valid for **one year**, renewing automatically unless either party
37 provides a **90-day notice** for termination.

38 **BENEFITS TO THE TOWN**

- 39 1. **Faster Power Restoration** – Having a dedicated staging area in Ponce Inlet enhances
40 FPL’s ability to quickly restore power to residents and businesses after a storm.
- 41 2. **Minimal Financial Impact** – The agreement does not impose costs on the Town. FPL
42 assumes responsibility for all staging-related expenses.
- 43 3. **Improved Emergency Preparedness** – Establishing this location strengthens the
44 Town’s overall disaster response plan and reinforces its commitment to public safety.

45 **RECOMMENDATION**

46 The Agreement has been reviewed by the Town Attorney for legal form and content. Staff
47 recommends that the Town Council approve the **Staging Area Agreement** with FPL and
48 authorize the Town Manager to execute the agreement.

49 **Attachment:**

1. Staging Area Agreement

STAGING AREA AGREEMENT

THIS STAGING AREA AGREEMENT is made and entered into as of the ____ day of March, 2025 (“**Agreement**”) by and between the Town of Ponce Inlet, a municipal corporation of the State of Florida with an address at 4300 S. Atlantic Ave., Ponce Inlet, FL 32127 (“**Grantor**”), and Florida Power & Light Company, a Florida corporation with an address at 700 Universe Blvd., Juno Beach, FL 33408 (“**FPL**”).

WITNESSETH:

WHEREAS, Grantor is the owner of real property located at 4670 S. Peninsula Drive., Ponce Inlet, Florida 32127 (the “**Property**”), as more fully described in Exhibit “A”, attached hereto and incorporated herein by this reference; and

WHEREAS, in the event of natural disasters or other emergency events that result in electrical power loss, FPL seeks temporary use of the Property as a staging area to store vehicles, equipment, and materials, and to coordinate response and restoration efforts; and

WHEREAS, Grantor agrees to grant FPL temporary, non-exclusive use the Property as a staging area for such purposes, subject to the terms and conditions set forth in this Agreement.

NOW, THEREFORE, in consideration of the above recitals, the mutual covenants, agreements and promises contained herein, and other good and valuable consideration, the receipt, adequacy, and sufficiency of which are hereby acknowledged, the parties agree as follows:

1. **Recitals.** The recitals stated above are adopted by the parties as findings of fact and are hereby incorporated into the body of this Agreement.

2. **Grant of Use.** Subject to the terms and conditions contained herein, Grantor hereby grants to FPL permission to enter the Property and the nonexclusive use of the Property as a staging area during local, state, and federal states of emergency, declared disasters such as major storms or hurricanes, and military or civil disturbances, to park trucks, stage employee vehicles, store equipment, and serve as an assembly site for FPL employees, contractors, and other utilities assisting FPL. The parties acknowledge and agree that no compensation or other consideration is to be provided by either party. FPL accepts the Property in its “as-is” condition as of the effective date of this Agreement.

3. **Request for Use.** Access to or use of the Property shall be approved in writing by Grantor upon FPL’s request. Requests for use of the Property shall be directed to the Ponce Inlet Public Safety Director, prior to each use.

4. **Property Access.** Upon Grantor’s approval, FPL may access the Property twenty-four (24) hours a day, seven (7) days a week, on an as-needed basis, for as long as reasonably necessary for FPL to reinstall or restore utility services. The parties expressly acknowledge and agree that FPL shall be solely responsible for the cost of any radiomen, signage, barricades, fencing, and the like, which is necessary to protect the public during FPL’s use of the Property.

5. **Property Restoration.** Within no more than ten (10) calendar days following FPL's use of the Property, FPL shall, at its sole cost and expense, restore the Property to its original condition prior to FPL's use.

6. **Security.** FPL agrees to take all necessary measures to secure the Property from public access while the FPL uses the Property as a staging area. FPL agrees to secure the staging area against theft, vandalism, and site abuse, and shall provide temporary lighting to ensure the safety of its equipment. FPL understands and agrees that Grantor assumes no liability for any damage to any vehicle, equipment, or other materials stored on or at the Property.

7. **Indemnification.** FPL agrees to protect, defend, indemnify and hold Grantor, its tenants, and their officers, directors, partners, affiliates, subsidiaries, employees, agents, and servants ("**Grantor Entities**") free and unharmed from and against any and all third-party claims (including employees of FPL, other utilities assisting FPL, and its contractors), liabilities, losses, costs, property damage, personal injury, bodily injury or death or damages whatsoever, including court costs and reasonable attorneys' fees, resulting from or in connection with the use of the Property by FPL and its contractors, including ingress and egress thereto, unless such claims are caused by Grantor's intentional acts or negligence. FPL will also reimburse Grantor for damages sustained as a result of the negligence of its employees or the employees of its contractors or other utilities assisting FPL. Nothing herein shall be interpreted to constitute a waiver of Grantor's sovereign immunity as set forth in Section 726.28, *Florida Statutes*. The provisions and obligations of this Section shall survive the expiration or earlier termination of this Agreement.

8. **Property Improvements.** FPL will provide, at its sole cost, any surface improvements it deems necessary for the effective use of the Property as a staging area, such as required utility services, sanitation facilities, fuel dispensing for its equipment, mobile office facilities, tents, eating facilities. If Grantor shall elect to supply water, gas, electricity, or any other utility service, FPL agrees to purchase same from Grantor and to pay the reasonable charges therefor when bills are rendered at the applicable rates. FPL shall use reasonable diligence in the conservation of these utilities.

9. **Term.** This Agreement shall be for a term of one (1) year commencing on the date set forth above and automatically renewed from year to year thereafter until one party gives the other party no less than ninety (90) days' written notice prior to the anniversary date that the Agreement will not be renewed for the following year.

10. **Hazards.** FPL acknowledges and agrees that in the event Grantor determines, in its sole discretion, that FPL's use of the Property creates a public safety hazard, FPL shall be required, at FPL's sole cost and expense, to take all necessary actions to remedy such hazard(s) as directed by Grantor.

11. **Amendment; Waiver; Severability.** This Agreement may be amended only by written instrument executed by an authorized representative of each of the parties hereto. No covenant, term, or condition of this Agreement shall be deemed to have been waived by Grantor unless such waiver is in writing and signed by Grantor. The waiver by Grantor of any breach of

any term, covenant, or condition herein contained shall not be deemed to be a waiver of such term, covenant, or condition for any subsequent breach of the same or any other term, covenant, or condition herein contained. Subject to applicable laws, the invalidity or unenforceability of any specific provision in this Agreement shall not render any other provision(s) invalid, inoperative, or unenforceable.

12. **Non-Assignment.** Nothing contained herein shall be deemed to confer upon FPL, or any person claiming by or through FPL, any right to use or occupy the Property except as expressly provided herein. FPL expressly covenants that it shall not by operation of law or otherwise assign its rights under this Agreement or suffer or permit the Property or any part thereof to be used by others. Any attempt by FPL to assign or otherwise grant any rights in the Property to any third party without the express consent of Grantor shall be null and void.

13. **Limitation of Rights.** FPL expressly acknowledges and agrees that no property or other right is created herein other than those rights specifically defined and limited by this Agreement.

14. **Insurance.** FPL is self-insured and maintains a comprehensive property and liability insurance program with deductibles of \$3,000,000.00 per occurrence.

15. **Governing law; Venue; Waiver of Jury Trial.** This Agreement will be construed in accordance with and governed by the laws of the State of Florida. Venue for any action arising under this Agreement shall be in the state or federal courts having jurisdiction in Volusia County, Florida. **The parties knowingly, voluntarily, and intentionally waive the right they may have to a trial by jury in respect of any litigation based hereon, or arising out of, under, or in connection with this Agreement, or any document contemplated to be executed in conjunction herewith, or any course of conduct, course of dealing, statement (whether oral or written), or action of either party.**

16. **Binding Effect.** This Agreement shall be binding upon and inure to the benefit of the parties hereto, their heirs, personal representatives, successors, and/or assigns.

17. **Entire Agreement.** This Agreement, including all referenced exhibits attached hereto, constitutes the entire agreement between the parties and shall supersede, replace, and nullify all prior agreements or understandings, written or oral, relating to the matters set forth herein.

[Signatures on Next Page]

IN WITNESS WHEREOF, the parties have caused this Agreement to be signed by their duly authorized officers or representatives effective as of the date first above written.

Grantor:

TOWN OF PONCE INLET

ATTEST:

By: _____

By: _____

Name: _____

Name: _____

Title: _____

Title: _____

Date: _____

Date: _____

FPL:

Florida Power & Light Company
A Florida corporation

By: _____
Matthew G. Ulman, Vice President
Integrated Supply Chain

EXHIBIT A

Description of Staging Area

As an attachment to the Staging Area Agreement between made and entered into as of the ____ day of March, 2025 by and between the Town of Ponce Inlet, Florida (“**Grantor**”) and Florida Power & Light Company (“**FPL**”).

An area described on this date as the Ponce Inlet Community Center located at 4670 S. Peninsula Dr., Ponce Inlet, Florida 32127 (Parcel ID #: 641901000075).





Meeting Date: 3/20/2025

Agenda Item: 13-B

Report to Town Council

Topic: Acceptance of bid from Accurate Power and Technology, Inc. for the replacement Fire Station generator.

Summary: See attached staff report and supporting documents.

Suggested motion: Staff recommends the award of Bid 2024-05, to Accurate Power and Technology for \$58,980 and authorize the Town Manager to execute all necessary agreements to proceed with the project.

Requested by: Mr. Wargo, Public Works Director

Approved by: Mr. Disher, Town Manager



MEMORANDUM

TOWN OF PONCE INLET, PUBLIC WORKS DEPARTMENT

The Town of Ponce Inlet staff shall be professional, caring and fair in delivering community excellence while ensuring Ponce Inlet residents obtain the greatest value for their tax dollar.

To: Michael E. Disher, AICP, Town Manager

From: Steven Wargo, Public Works Director

Date: February 4, 2025

Subject: Replacement Emergency Generator – Fire Department

MEETING DATE: March 20, 2025

Background:

The current emergency generator at the Ponce Inlet Fire Station has been in place since 1997. It has now reached the end of its service life and requires replacement to ensure uninterrupted emergency operations. Recognizing the critical need for reliable power during emergencies, last year the Town requested and received a \$35,000 appropriation from the Florida Legislature and set aside 50% matching funds in the adopted FY 24/25 budget. This past October, Town staff received the grant documents from the Florida Division of State Fire Marshal needed prior to putting the project out for bid.

Bid Process:

The Town advertised Bid #2024-05 for the replacement and installation of an emergency generator in accordance with procurement policies. Three bids were received and evaluated based on cost, compliance with the bid specifications, and contractor qualifications:

- Accurate Power and Technology: \$58,980
- DDS Enterprises: \$78,000
- Zabbatt Engine Services: \$106,155.03

Accurate Power and Technology provided the lowest bid and demonstrated the capability to meet all project requirements within the available budget.

Fiscal Impact:

This is step one of a two-step process. The matching funds, currently located in contingency and

the fire capital equipment fund, will be transferred to the Public Works budget through a transfer of appropriations at the April regular Council meeting.

The total project cost of \$58,980 is fully covered by the combined \$35,000 grant from the Florida Division of State Fire Marshal and a \$35,000 match allocated in the current FY 24/25 Town budget. Total funds available for the project are \$70,000, with the remaining funds available for any unforeseen project-related expenses.

Recommendation:

Staff recommends that the Town Council approve the award of Bid #2024-05 to Accurate Power and Technology for \$58,980 and authorize the Town Manager to execute all necessary agreements to proceed with the project.



15519 U.S. Hwy 441
Suite A101
Eustis, FL 32726
Office: 352-735-8285
Fax: 352-609-5165

Accurate Power and Technology, Inc is a State Certified Electrical Contractor since 2005, (S-CORP) EIN (20-2663060), LIC (EC13007737) DUNS (36-247-2800) E-Verify (1651230) that specializes in Back Up Power and Commercial Electric. It is our intent to Contract with Ponce Inlet for RFP24-005.

We understand the scope defined as Supply and install a Generator and switch for replacement. No Exceptions are taken for this submittal. All work to be completed with the upmost quality and in a timely manner consciously and having the cities best interest in mind.

Accurate Power currently holds "Brick and Mortar" in Central Florida (Eustis) and the West Coast of Florida (Sarasota).

Accurate Power Manages approx. 5500 Engines around the state.

1. **Eustis – 15519 West US Highway 441 Suite A101 Eustis, FL 32726 (352.735.8285 Office) (Proposing Office) (352.609.5165 FAX)**
2. **Sarasota – 6341 Porter Road Unit 8 Sarasota, FI 34240 (941.867.6580 Office)**

Below is a list of Full Time Employees and procedure:

1. Sonny J Dukes, President, Lead Industrial Technical Advisor 6σ, 407.280.7904
2. Shannon M Dukes, VP, PMP, MBA 352.735.8285
3. Jack Phillips, EC Qualifier 727.858.0687
4. David Kornstadt, Commercial AE 352.805.5024
5. Haley Bogart AR/AP 352.735.8285
6. Brian Eakin, Operations Manager, Lead Certified Industrial Technician 352.735.8285
7. Chris Ethridge, Lead Electrical, Lic Journeyman, Staff Engineer and Estimator 352.735.8285
8. Toni Hayden, Service Manager, Parts, Warranty and Quoting 352.735.8285
9. Allen Green – Lead Industrial Diesel 352.735.8285
10. On-Call 352.735.8285 (prompts)

We are currently staffed to complete 12 million in Revenue annually. **Our service department supports some large clients to date such as FDOT, Seminole County,**

Mt Dora, Pinellas County Schools, Orlando Utilities, City of Altamonte Spring, Florida Keys, FDVA, FDEMS, and FDEMS. We also support several “Life Safety” Clients such as nursing homes and assisted living facilities. All 24 of our Vehicles are 2018/2019/2022 and are either owned by us or Enterprise Fleet. All (Uniformed)Technicians hold Jessica Lunsford certification.

All contents of this proposal are true and accurate, all requirements for this Bid Proposal can be met, including, but not limited to, insurance, bonding, and licensing, and Certifications.

MISSION STATEMENT AND CORE VALUES

Accurate Power and technology provide the best possible cutting-edge backup power product for any budget. We focus on the best value and service across every client we serve.

1. We believe our employees come first and we respect our suppliers.
2. We stay involved in our community and are dedicated to our chosen organizations to help less fortunate.
3. We have passion for execution.
4. We will be experience focused rather than price.
5. We will strive to achieve 100% customer satisfaction.

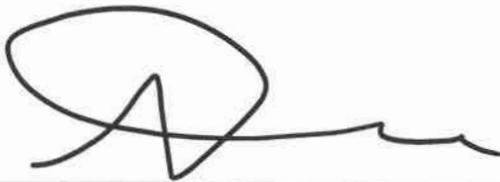

_____, President 11/20/2024

Sonny J Dukes
Controller, Accurate Power and Technology, Inc
EC13007737
6σ, ITIL, NET+, SEC+
OFFICE: 352.735.8285
15519 West US Highway 441
Suite 101A
Eustis, FL 32726

Fire Station Generator

REQUEST FOR PROPOSAL (RFP)

Scope of Work:

The Town of Ponce Inlet is requesting a proposal for an emergency generator for the Fire Station located at 4680 South Peninsula Drive, Ponce Inlet Florida 32127. Proposals shall be submitted based on the purchase, installation, and integration of a 40Kw standby generator. The 40Kw generator can be either diesel or propane powered.

The Generator will be protected against a 500-year flood event or 7 feet above sea level by implementing specific activities or by locating the generator outside the Special Flood Hazard Area (SFHA) and will be protected against wind with a rated enclosure based on its location requirements. Activities will be completed in strict compliance with Federal, State and Local Rules and Regulations.

The Generator shall be designed/constructed/installed in accordance with the International Code Council’s ICC/NSSA Standard for the Design and Construction of Storm Shelters (ICC 500-2014) or, where hurricane provisions are more stringent, NFPA 70E 2020, the 2023 Florida Building Code, 8th Edition (Risk Category IV Buildings).

The contractor will be responsible for the permit and engineering to install and integrate the generator to Public Works. After completion of the integration of the generator the contractor will provide a one-hour training session about the generator to Public Works staff.

Deadline:

Please return this Request for Proposal Form addressed to Town Clerk, Town of Ponce Inlet, 4300 S. Atlantic Avenue, Ponce Inlet, FL 32127 in a SEALED ENVELOPE plainly marked on the outside **RFP 2024-05 Fire Station Generator** with a Lump Sum Price by with a Lump Sum Price by **2:00 pm, Monday December 30, 2024.**

Scope of Work:

Lump Sum/Unit Pricing:

ITEM NO.	DESCRIPTION	EST QUANTITY	UNIT	AMOUNT PROPOSAL
1	40Kw Generator Project	1	LS	\$ 58,980.00
1	ATS Replacement Alt	1	LS	\$ 21,013.00
LUMP SUM TOTAL				

NOTE: This is for LUMP SUM COST of the entire project, unit prices are to establish pricing if additional work is required above or beyond the Lump Sum Base Price.

Vendor Name:	Sonny J. Dikes	Date:	12.17.24
Company:	Accurate Power and Technology Inc		
Phone #:	352.765.8285	eMail:	sonny@accuratepowerandtechnology.com
Signature:		Print Name:	Sonny J. Dikes

Attachment F

**Certification Regarding
Debarment, Suspension, Ineligibility
And Voluntary Exclusion**

Subcontractor Covered Transactions

No Subs to be used

- (1) The prospective subcontractor, _____, of the Recipient certifies, by submission of this document, that neither it nor its principals is presently debarred, suspended, proposed for debarment, declared ineligible, or voluntarily excluded from participation in this transaction by any Federal department or agency.
- (2) Where the Recipient's subcontractor is unable to certify to the above statement, the prospective subcontractor shall attach an explanation to this form.

SUBCONTRACTOR:

[Handwritten Signature]
Sonny J. Dukes, President

By: _____
Signature

Recipient's Name

Name and Title

DEM Contract Number

Street Address

Project Number

City, State, Zip

Date

NON-COLLUSION AFFIDAVIT

I, Sonny J. Dukes, depose and say that:

1. I am President of the firm Accurate Power & Tech. the firm submitting the response described in this Request for Proposals; and that I executed the said response with full authority to do so;
2. The prices in this bid have been arrived at independently without collusion, consultation, communication, or agreement for the purpose of restricting competition, as to any matter relating to such prices with any other bidder or with any competitor;
3. Unless otherwise required by law, the prices which have been quoted in this bid have not been knowingly disclosed by the bidder and will not knowingly be disclosed by the bidder prior to bid opening, directly or indirectly, to any other bidder or to any competitor;
4. No attempt has been made or will be made by the bidder to induce any other person, partnership, or corporation to submit, or not to submit, a bid for the purpose of restricting competition; and
5. The statements contained in this affidavit are true and correct, and made with full knowledge that the Town of Ponce Inlet relies upon the truth of the statements contained in this affidavit in awarding contracts for said project.

[Signature]
Bidder's Signature

12-17-24
Date Signed

STATE OF: Florida COUNTY OF: Lake

The foregoing instrument was acknowledged before me by means of physical presence or online notarization this 17 day of Dec, 2024, by Sonny Dukes as authorized representative of the bidder agency submitting this packet.

[Signature]
Notary Signature

Notary Stamp/Seal: State of Florida
Kimberly Slotnick
My Commission HH 617721
Expires 3/22/2029

Personally known OR Produced Identification: _____
Type of ID presented: _____

Request for Taxpayer Identification Number and Certification

► Go to www.irs.gov/FormW9 for instructions and the latest information.

Give Form to the requester. Do not send to the IRS.

1 Name (as shown on your income tax return). Name is required on this line; do not leave this line blank.
Accurate Power and Technology, Inc

2 Business name/disregarded entity name, if different from above
A Generator Guy

3 Check appropriate box for federal tax classification of the person whose name is entered on line 1. Check only **one** of the following seven boxes.

Individual/sole proprietor or single-member LLC C Corporation S Corporation Partnership Trust/estate

Limited liability company. Enter the tax classification (C=C corporation, S=S corporation, P=Partnership) ► _____

Note: Check the appropriate box in the line above for the tax classification of the single-member owner. Do not check LLC if the LLC is classified as a single-member LLC that is disregarded from the owner unless the owner of the LLC is another LLC that is **not** disregarded from the owner for U.S. federal tax purposes. Otherwise, a single-member LLC that is disregarded from the owner should check the appropriate box for the tax classification of its owner.

Other (see instructions) ► _____

4 Exemptions (codes apply only to certain entities, not individuals; see instructions on page 3):
Exempt payee code (if any) _____
Exemption from FATCA reporting code (if any) _____
(Applies to accounts maintained outside the U.S.)

5 Address (number, street, and apt. or suite no.) See instructions.
15519 West Us Highway 441 Suite A101

6 City, state, and ZIP code
Eustis, FL 32726

7 List account number(s) here (optional)

Requester's name and address (optional)

Part I Taxpayer Identification Number (TIN)

Enter your TIN in the appropriate box. The TIN provided must match the name given on line 1 to avoid backup withholding. For individuals, this is generally your social security number (SSN). However, for a resident alien, sole proprietor, or disregarded entity, see the instructions for Part I, later. For other entities, it is your employer identification number (EIN). If you do not have a number, see *How to get a TIN*, later.

Social security number

				-						
--	--	--	--	---	--	--	--	--	--	--

OR

Employer identification number

2	0	-	2	6	6	3	0	6	0
---	---	---	---	---	---	---	---	---	---

Note: If the account is in more than one name, see the instructions for line 1. Also see *What Name and Number To Give the Requester* for guidelines on whose number to enter.

Part II Certification

Under penalties of perjury, I certify that:

- The number shown on this form is my correct taxpayer identification number (or I am waiting for a number to be issued to me); and
- I am not subject to backup withholding because: (a) I am exempt from backup withholding, or (b) I have not been notified by the Internal Revenue Service (IRS) that I am subject to backup withholding as a result of a failure to report all interest or dividends, or (c) the IRS has notified me that I am no longer subject to backup withholding; and
- I am a U.S. citizen or other U.S. person (defined below); and
- The FATCA code(s) entered on this form (if any) indicating that I am exempt from FATCA reporting is correct.

Certification instructions. You must cross out item 2 above if you have been notified by the IRS that you are currently subject to backup withholding because you have failed to report all interest and dividends on your tax return. For real estate transactions, item 2 does not apply. For mortgage interest paid, acquisition or abandonment of secured property, cancellation of debt, contributions to an individual retirement arrangement (IRA), and generally, payments other than interest and dividends, you are not required to sign the certification, but you must provide your correct TIN. See the instructions for Part II, later.

Sign Here Signature of U.S. person ► *Sonny Dukas* Date ► 1/1/2025

General Instructions

Section references are to the Internal Revenue Code unless otherwise noted.

Future developments. For the latest information about developments related to Form W-9 and its instructions, such as legislation enacted after they were published, go to www.irs.gov/FormW9.

Purpose of Form

An individual or entity (Form W-9 requester) who is required to file an information return with the IRS must obtain your correct taxpayer identification number (TIN) which may be your social security number (SSN), individual taxpayer identification number (ITIN), adoption taxpayer identification number (ATIN), or employer identification number (EIN), to report on an information return the amount paid to you, or other amount reportable on an information return. Examples of information returns include, but are not limited to, the following.

- Form 1099-INT (interest earned or paid)

- Form 1099-DIV (dividends, including those from stocks or mutual funds)
 - Form 1099-MISC (various types of income, prizes, awards, or gross proceeds)
 - Form 1099-B (stock or mutual fund sales and certain other transactions by brokers)
 - Form 1099-S (proceeds from real estate transactions)
 - Form 1099-K (merchant card and third party network transactions)
 - Form 1098 (home mortgage interest), 1098-E (student loan interest), 1098-T (tuition)
 - Form 1099-C (canceled debt)
 - Form 1099-A (acquisition or abandonment of secured property)
- Use Form W-9 only if you are a U.S. person (including a resident alien), to provide your correct TIN.

If you do not return Form W-9 to the requester with a TIN, you might be subject to backup withholding. See *What is backup withholding*, later.



Addendum #1

Town of Ponce Inlet

Fire Department Generator - RFP No. 2024-05

Q&A

1. *What is the estimated budget for the 40Kw generator project?*

Answer – \$70,000.

Please also include proof of insurance with proposal.



Sonny D Deeks President

Debbie Stewart, Assistant Deputy Clerk
Addendum #1 – dated 11/13/2024



Addendum #2

Town of Ponce Inlet

Fire Department Generator - RFP No. 2024-05

Q&A from Pre-Bid Meeting 11/20/2024

1. *What are you looking for?*

Answer – One for one swap of the current generator as long as it meets current codes listed in the scope of work.

2. *What about the transfer switch?*

Answer – Add a new transfer switch (if needed) as an alternate to the proposal.

3. **Generator must be industrial grade not residential grade.**

 President
Sony J. Dees.

Debbie Stewart, Assistant Deputy Clerk
Addendum #1 – dated 11/13/2024



Addendum #3

Town of Ponce Inlet

Fire Department Generator - RFP No. 2024-05

1. *Can you please expand on the statement in the posting,*

"The Generator will be protected against a 500-year flood event or 7 feet above sea level by implementing specific activities or by locating the generator outside the Special Flood Hazard Area (SFHA)".

Beyond supplying and installing the generator, is there additional engineering and site work to be expected? For example, building an elevated platform to meet the above sea level requirement.

Answer – Yes, additional engineering and site work will need to be performed to place the generator at the proper height to meet the regulations.

Sony J. Deha. President

Debbie Stewart, Assistant Deputy Clerk
Addendum #3 – dated 12/10/2024



Addendum #4

Town of Ponce Inlet

Fire Department Generator - RFP No. 2024-05

1. *We believe that all bidders should be attempting to bid the same project. You are requesting an either or on generator type of diesel or propane. Propane will require a 3rd party propane supplier with tanks that could be purchased or perhaps leased. As diesel is existing at the Fire Station we request all bidders quote diesel generators.*

Answer – The RFP lists the proposal requirements. It is up to the bidders to determine what they will bid on.

2. *Who will be responsible for existing fuel removal and new fuel?*

Answer - New Fuel will be the responsibility of the Town. Bidders will need to provide enough fuel for the final test of the generator.

3. *What are we to do with the old generator from the Fire Station?*

Answer - Remove and properly dispose.

4. *Please confirm that there is no remote annunciator.*

Answer - Bidders can review the project site at any time prior to the bids being due.

5. *Confirm the intent is to reuse the existing wiring.*

Answer - As long as it meets code requirements.

6. *Will any bollards be required at the Community Center?*

Answer - Not for this bid.

7. *We understand the 500 year flood requirement spelled out in Addendum 3 however, it would help keep all bidders on the same page if we knew what the current elevations were for the 2 parking spaces and the existing generator pad. Please advise.*

Answer - That is for the bidders to determine.

8. *We are concerned about the existing utility service size for the Community Center. The main in the panel is 300 amps however, the incoming utility feed to the meter is 350 MCM aluminum, which is rated at 250 amps. We could not tell the wire size for the load (Main Panel) but it would need to be 500 MCM aluminum to be rated for the 300 amp main breaker. As a 300 amp Service entrance rated ATS will be almost impossible to find and the service is 3 phase, we are requesting that the owner reach out to the*

electrical utility for the peak KW draw by month over the last 12 months. This will greatly assist in providing the proper transfer switch and or main disconnect.

Answer – The Town will review and send out as an additional addendum.

9. *At the Fire Department please advise how the existing ATS is fed, its location and amperage rating.*

Answer - Bidders can review the project site at any time prior to the bids being due.

10. *Are there any special generator start up requirements?*

Answer - Standard regulation requirements.

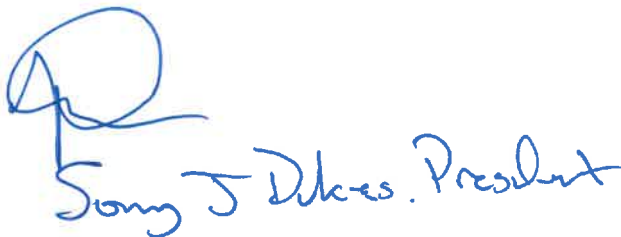

Sony J. DeKes. President

Debbie Stewart, Assistant Deputy Clerk
Addendum #4 – dated 12/11/2024



Addendum #5

Town of Ponce Inlet

Fire Department Generator - RFP No. 2024-05

1. Are there Liquidated damages and are they capped?

Answer – No.

2. What is the warranty period?

Answer – 1-year labor and the manufacturer's warranty.

3. Is there Force majeure language that uncontrollable events do not cause default and provide an extension of time to complete?

Answer - There is not a completion date at this point.

4. Is there Mutual waiver of consequential damages? If not, can it be added?

Answer – Not at this time.

5. Is a bid bond required for this bid? If so, will the obligee allow the use of AIA bond forms?

Answer – No bid bond required.

6. What is the substantial and final completion?

Answer – That will be based on the manufacturer's delivery date of the generators.

Sonny J. Dekes, President

Debbie Stewart, Assistant Deputy Clerk
Addendum #5 – dated 12/11/2024



15519 U.S. Hwy 441
Eustis, FL 32726
Office: 352-735-8285
Fax: 352-609-5165

Qualifications and Experience

Accurate Power and Technology, Inc is a State Certified Electrical Contractor that specializes in Back Up Power and Commercial Electrical Service. Our Mission Statement and Core Values will explain our required commitment to customer satisfaction and businesslike concerns for our clients.

MISSION STATEMENT AND CORE VALUES

Accurate Power and technology provide the best possible cutting-edge backup power product for any budget. We focus on the best value and service across every client we serve.

1. We believe our employees come first and we respect our suppliers.
2. We stay involved in our community and are dedicated to our chosen organizations to help less fortunate.
3. We have passion for execution.
4. We will be experience focused rather than price.
5. We will strive to achieve 100% customer satisfaction.

We have successfully completed administratively and Operationally Major Service and Installation work for several large clients including. We have never missed a budget or schedule. Below we have listed some of the contracts we have held over the last 10 years

1. Department of Transportation (**MOT Certified**)
2. Department of Agriculture
3. Florida Department of Health
4. Orange County
5. Lake County
6. Pinellas County Schools Board
7. City of Altamonte Springs
8. Orlando Utilities
9. Lee County School Board
10. St Johns County School Board
11. DMS
12. DEMS
13. City of Daytona Beach
14. Key West Electrical Co-Op

15. Tarpon Springs
16. Punta Gorda
17. Sarasota County
18. Orange County Convention Center
19. City of Casselberry
20. Manatee County

Below is a list of Employees and procedure:

1. Sonny J Dukes, President, Lead Industrial Tech, 6σ 407.280.7904
2. Shannon M Dukes VP, PMP, MBA 352.735.8285
3. Jack Phillips, EC Qualifier 727.858.0687
4. David Kornstadt, Commercial AE 352.805.5024
5. Haley Bogart AR/AP 352.735.8285
6. Brian Eakin, Operations Manager – 352.735.8285
7. Brian Eakin, Lead/Certified Industrial Technician 352.735.8285
8. Chris Ethridge – Lead Engineering and Senior Electrician, Lic Journeyman, Estimator.
9. Kim Slotnick – Project Coordinator 352.735.8285
10. Toni Hayden, Service Manager, Parts, Warranty and Commercial 352.735.8285
11. Allen Green – Lead Industrial Technician/Trainer 352.735.8285
12. On-Call 352.735.8285

We are currently staffed to complete 10 million in Revenue annually. **Our service department supports some large clients to date such as the City of Eustis, Mt Dora, Lake County, and Department of Transportation. We also support several “Life Safety” Clients such as nursing homes and assisted living facilities.** All 30 of our Vehicles are 2020-2022 and are either owned by us or Enterprise Fleet. Our Company was started in 2005 and has over 3500 Residential, Commercial, and Industrial Clients.

Accurate Power and Technology is open Monday thru Friday from 0800 to 1730

Accurate Power and Technology, Inc Currently employees 48 individuals from Permit Technicians, Service Technicians to Electrical Installation Technicians.

Accurate Power and Technology resides in Eustis, Fl housing around 5000sqr/ft of rented space. We also own free and clear an acre of property in Mt Dora located

on 441 where we intend to build the future office. Both are secure and house cameras.

Accurate Power holds Brick and Mortar in Eustis, and Sarasota

Accurate Power and Technology can accommodate walk-ins and scheduled appointments. We can usually respond to appointment requests and accommodate most any time and date during normal day and times.

When emergencies arise Accurate Power and Technology will ensure The School District is given priority for repair and call outs.

Our Uniformed techs are completely qualified and have the tools on hand to complete most of the work that would be needed. EX..

1. Air Tools and Compressors.
2. Pumps.
3. Safety Clean supply's our Oil and AF.
4. Welders
5. Calibrated Meters and complete PPE
6. We are building a truck to carry Fuel 200 gallons for emergencies.
7. Torque wrenches
8. Laptop and software for ATS's and Engine Diagnostic Tools.
9. 500KW and 6-100KW Load Banks in inventory. The Upper Sizes are rented to 2M.
10. Fuel Testing (Polaris Labs)
11. Fuel Polishing (In House)
12. OSHA 10-40, NFPA110 training held in house. Certified Trainer

All contents of this proposal are true and accurate.

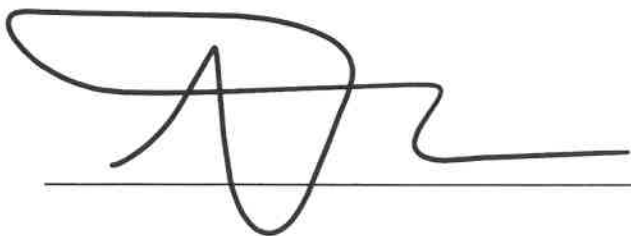
A handwritten signature in black ink, consisting of a large, stylized initial 'A' followed by a horizontal line and a small flourish.

President 11/20/2024



Ron DeSantis, Governor

Melanie S. Griffin, Secretary



STATE OF FLORIDA
DEPARTMENT OF BUSINESS AND PROFESSIONAL REGULATION

ELECTRICAL CONTRACTORS' LICENSING BOARD

THE ELECTRICAL CONTRACTOR HEREIN IS CERTIFIED UNDER THE
PROVISIONS OF CHAPTER 489, FLORIDA STATUTES

Additional Business Qualification

PHILLIPS, JACK E
A GENERATOR GUY
32744 SCENIC HILLS DRIVE
MOUNT DORA FL 32757

LICENSE NUMBER: EC13007737

EXPIRATION DATE: AUGUST 31, 2026

Always verify licenses online at MyFloridaLicense.com

ISSUED: 07/02/2024

Do not alter this document in any form.

This is your license. It is unlawful for anyone other than the licensee to use this document.



**EVALUATION OF PAST PERFORMANCE –
ENCLOSE THREE (3) REFERENCES WITH THE BID**

(Please type or clearly print below)

To be completed by the Bidder:

Bidder or Associated Business Entity's Name: Accurate Power and Technology

Company Representative: Chris Eldrige

Bidder's Phone Number: 352 735-8285

REFERENCE:

Reference Organization Name: City of Winter Springs

Reference Contact: Leonard Hartman

Reference Phone Number: 407 327-7580

Reference Email Address: Lhartman@winterspringsfl.org

Briefly describe the work performed for the above Reference:

Installed 26 light poles and LED Lights.

The following questions will be asked of the client reference as chosen at the discretion of the Department.

1. How well did the contractor adhere to the agreed upon schedule?

Excellent XX Above Satisfactory _____ Satisfactory _____ Fair _____

Poor _____

Comments: Contractor met each deadline.

2. How would you rate the contractor's overall quality of work?

Excellent XX Above Satisfactory _____ Satisfactory _____ Fair _____

Poor _____

Comments: Contractor did a great job.

3. How would you rate the contractor's use of adequate personnel in quantity, experience and professionalism?

Excellent XX Above Satisfactory _____ Satisfactory _____ Fair _____

Poor _____

Comments:

4. How would you rate the contractor's use of appropriate equipment and methods?

Excellent XX Above Satisfactory _____ Satisfactory _____ Fair _____

SCORING:

Excellent = 4 4 points

Above Satisfactory = 3 points

Satisfactory = 2 points

Fair = 1 point

Poor = 0 points

Total Score = 16

Average (Total Score/4) = 4

Reference Signature: Len Hartman

Date: 2024-10-31

3.3 BUSINESS REFERENCES

The Proposer must submit at least **THREE (3) REFERENCES WITH THE SUBMITTED PROPOSAL**. HCPS may contact these references to predict the quality of goods and services. False references, in HCPS' sole discretion, may be cause for Proposer's disqualification. **DO NOT IDENTIFY HCPS AS A REFERENCE.**

- Included references should be customers from the previous three (3) years; and
- HCPS-Preferred references shall be in the following order: School districts, Hillsborough County, Florida based references, State of Florida based references, Large municipalities or local governments, and the private sector.

In response to this Hillsborough County Public Schools' competitive solicitation, Proposer (Proposer Name):

Acecorate Power and Technology Inc states that they have provided similar goods and services to your firm. Please respond as to the quality of the provided goods and services. Return this form as soon as possible to the firm for proposal submission. The filled-in references are due with their proposal.

Pinellas County Schools
 Referenced Firm's Name

11111 S. Delcher RD. Largo. FL. 32773
 Address

Mike McClimon
 Contact Person

mcclimonm@pcsb.org Phone Number 727.638.3373

X Yes No: Would you use this contractor again?
 X Yes No: May we contact you with additional questions?
 Total Dollar Amount of Contract: \$350,000.00

Performance Rating: Excellent = 4, Good = 3, Fair = 2, Poor= 1, or N/A

DESCRIPTION OF PERFORMANCE	RATING
Overall Technical Performance. The Contractor's overall demonstrated technical performance.	<u>4</u>
Partnership. The Contractor's ability and attention to the quality of outcomes.	<u>4</u>
Responsiveness. The Contractor's ability to follow instructions, handle complaints, and communicate with custom staff.	<u>4</u>
Efficiency. The Contractor's overall effectiveness in planning, scheduling, monitoring, and problem-solving.	<u>4</u>
Uniformity of Goods/Service Reliability. The Contractor's timely delivery and uniform quality of provided goods and services.	<u>4</u>
Key Personnel/Management. The Contractor's ability to provide quality personnel and project oversight.	<u>4</u>
Overall Experience. Overall customer experience.	<u>4</u>

Additional Comments:
Great service, always there for emergencies. Keeps in contact about repairs and parts orders.

mike mcclimon Date 07/22/2024
 Contact Person Signature

**EVALUATION OF PAST PERFORMANCE –
ENCLOSE THREE (3) REFERENCES WITH THE BID**
(Please type or clearly print below)

To be completed by the Bidder:

Bidder or Associated Business Entity's Name: _____
Company Representative: _____
Bidder's Phone Number: _____

REFERENCE:

Reference Organization Name: Manatee County School District
Reference Contact: Steve Gill
Reference Phone Number: 941-932-7912
Reference Email Address: Gills@manateeschools.net

Briefly describe the work performed for the above Reference:

generator install

The following questions will be asked of the client reference as chosen at the discretion of the Department:

1. How well did the contractor adhere to the agreed upon schedule?

Excellent Above Satisfactory _____ Satisfactory _____ Fair _____ Poor _____

Comments: _____

2. How would you rate the contractor's overall quality of work?

Excellent Above Satisfactory _____ Satisfactory _____ Fair _____ Poor _____

Comments: _____

3. How would you rate the contractor's use of adequate personnel in quantity, experience and professionalism?

Excellent Above Satisfactory _____ Satisfactory _____ Fair _____ Poor _____

Comments: _____

4. How would you rate the contractor's use of appropriate equipment and methods?

Excellent Above Satisfactory _____ Satisfactory _____ Fair _____ Poor _____

Comments: _____

SCORING:

Excellent = 4 points
Above Satisfactory = 3 points
Satisfactory = 2 points
Fair = 1 point
Poor = 0 points

Total Score = 16

Average (Total Score/4) = 16

Reference Signature: _____

Date: 10/28/24

ATTACHMENT - 3

REFERENCE FORM

	The School Board of Seminole County, Florida Purchasing and Distribution Services Department 400 East Lake Mary Boulevard Sanford, Florida 32773
The Next Line To Be Completed by the Firm Being Referenced:	
Firm: <u>Lee County Schools.</u>	
School Board ITB Number and Title. <u>ITB #20210058B-CB – Generator P.M. and Repair</u>	

The School Board of Seminole County is currently evaluating qualifications of various firms to provide the above professional contract services and the indicated firm has listed you as a reference, having performed similar services for your organization. Please take a few moments to complete the following survey and return to firm requesting reference. Your assistance in providing this information is appreciated. ***Reference forms shall be included in your bid submittal.**

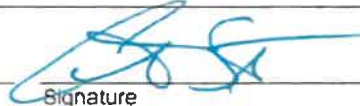
This Section To Be Completed by the Reference Provider:	
What specific services did this firm provide? <u>Generator PM and Service Contract</u>	
Was the firm responsive to your needs and requests?	<input checked="" type="checkbox"/> Yes <input type="checkbox"/> No
Was there good communication between the client and the firm?	<input checked="" type="checkbox"/> Yes <input type="checkbox"/> No
Was the firm proactive in resolving problems and disputes?	<input checked="" type="checkbox"/> Yes <input type="checkbox"/> No
Was the staff professional and knowledgeable?	<input checked="" type="checkbox"/> Yes <input type="checkbox"/> No
Were the services completed on time and within budget?	<input checked="" type="checkbox"/> Yes <input type="checkbox"/> No
Has this firm ever been awarded a repeat contract by your Organization for similar services?	<input checked="" type="checkbox"/> Yes <input type="checkbox"/> No
Would you award a contract to this firm again for similar services?	<input checked="" type="checkbox"/> Yes <input type="checkbox"/> No
How would you rate the overall performance of the firm?	
<input checked="" type="checkbox"/> Excellent <input type="checkbox"/> Very Good <input type="checkbox"/> Satisfactory <input type="checkbox"/> Unsatisfactory	
Comments: <u>ACCURATE POWER HAS PROVIDED EXCELLENT SERVICE TO OUR SCHOOL DISTRICT WE VALUE OUR PARTNERSHIP!</u>	
Name of Person Providing Information:	
<u>CHRISTOPHER STEUBER</u>	
Printed name	Signature
Title: <u>MAINTENANCE COORDINATOR</u>	Phone: <u>(239) 785-6368</u>
Company/Agency: <u>LEE COUNTY SCHOOL DISTRICT (LCSD)</u>	Date: <u>2-20-24</u>



PROPOSAL

IPS Power Systems

6312 78th street
Riverview, Florida 33578
www.ips.us

TOTAL NET VALUE

Accurate Power & Technology

15519 West Highway 441, Suite 101A
Eustis, FL 32726

Proposal #
Proposal Date
Project
Contact
Expires
Email
Mobile Number :
Branch

Attention: Chris Ethridge

ITEM & DESCRIPTION

AMOUNT

KOHLER Model 40REOZK , EPA Certified Diesel Generator Set
42kW, @ 0.8 PF, 60 Hz, 3 Phase, 277/480 Volt, alternator 4P7BX

APM 402 Controller meets NFPA 110
Enclosure: Sound Aluminum, 181 MPH Wind Load Rated, Critical Silencer

FLEXIBLE FUEL LINES
FUEL PRESSURE GAUGE ASSY
ASSY AIR CLEANER RESTRICTION IND.
Coolant in Genset 4 gals.
Oil in GenSet, 16.5 qt
Rodent Guard, 4PX

Sub-base Fuel Tank, 48 Hour, 229 Gallon, UL142
Fuel Water Separator
Line Circuit Breaker, 3 Pole, 100% Rated,
70-Amp, Thermal mag w/ Shunt Trip, Shunt Trip Wiring, aux contact
Software, Fuel Level&Fuel In Basin
Block Heater, 120V 1000W
Battery,1/12V,650CCA,Wet
Assy Battery Charger, 12V/24V, 10A
Generator Heater, 120/240V, 200W
Run Relay, 12V
Governor, Electronic, Kit
APM402/DEC3000 2 INPUT/5 OUTPUT

Battery Rack and Cables
Remote Emergency Stop, Lockable



ITEM & DESCRIPTION

AMOUNT

Remote Annunciator
Vibration Isolators: Internal

Certified Factory Test @ 0.8 P.F.
1 Engine, Generator Parts, Maintenance Manuals & 1 Electronic Manual

Warranty and Services:
5-year comprehensive Warranty
Start Up & On Site Load Bank Testing in Florida

Supplied by Others
Off-loading @ Job Site
Installation of System
Fuel & Electrical Piping
All Infrared, 3rd Party & NETA Testing
Supply of Fuel

Estimated Lead Time
13-15 weeks after release of order
Please note: The lead time provided represents the most current factory lead times and is subject to change at the time of order release

Exceptions / Clarifications / Notes: no other equipment or services provided other than those listed herein

Offer Based Upon: dealer email

Exceptions / Clarifications / Notes: No other equipment or services provided other than those listed herein

Offer Based Upon: dealer email

Delivery, Start up, and Load testing are quoted as during normal business hours. If after hours, weekend, or holiday work hours are required, the Contractor will be responsible for the overtime differential unless otherwise noted

F.O.B. Factory
Delivery in Florida provided (offload, set and installation services by others)
Sales Tax Not Included

****ADDITIONAL EXCEPTIONS & NOTES:**

Terms & Conditions

TAW Power Systems, Inc. STANDARD TERMS and CONDITIONS apply to all offers for purchase and any purchase orders accepted by TAW Power Systems, Inc. You may find a copy under the terms and conditions section at tawinc.com or please contact our office at 800-456-9449 and we will forward you a copy. TAW Power Systems, Inc. will transmit a written delivery schedule based on the manufacturer's confirmation, approximately fifteen (15) days after product release. Also





Tier 3 EPA-Certified for Stationary Emergency Applications
(Not for sale in California)

Ratings Range

		60 Hz
Standby:	kW	37-42
	kVA	37-52
Prime:	kW	34-37
	kVA	34-46

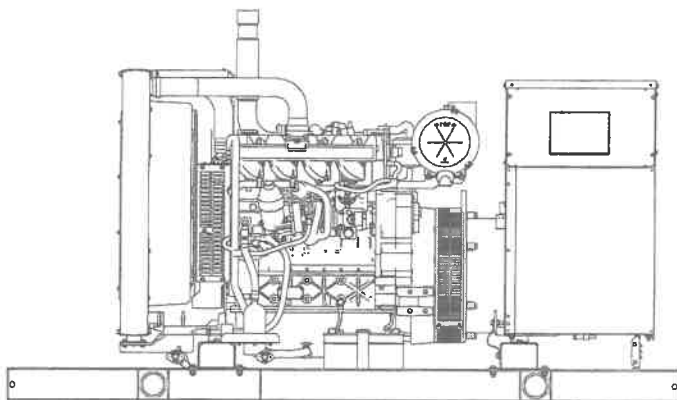

Standard Features

- Kohler Co. provides one-source responsibility for the generating system and accessories.
- The generator set and its components are prototype-tested, factory-built, and production-tested.
- The 60 Hz generator set offers a UL 2200 listing.
- The generator set accepts rated load in one step.
- The 60 Hz generator set meets NFPA 110, Level 1, when equipped with the necessary accessories and installed per NFPA standards.
- The generator set engine is certified to meet the Environmental Protection Agency (EPA) emergency stationary emissions requirements.
- A one-year limited warranty covers all generator set systems and components. Two- and five-year extended limited warranties are also available.
- Alternator features:
 - The unique Fast-Response® X excitation system delivers excellent voltage response and short-circuit capability using a rare-earth, permanent magnet (PM)-excited alternator.
 - The brushless, rotating-field alternator has broadrange reconnectability.
- Other features:
 - Kohler designed controllers for guaranteed system integration and remote communication. See Controllers on page 3.
 - The low coolant level shutdown prevents overheating (standard on radiator models only).
 - Integral vibration isolation eliminates the need for under-unit vibration spring isolators.

Generator Set Ratings

Alternator	Voltage	Ph	Hz	130°C Rise Standby Rating		105°C Rise Prime Rating	
				kW/kVA	Amps	kW/kVA	Amps
4P5X	120/208	3	60	42/52	145	37/46	128
	127/220	3	60	42/52	137	37/46	121
	120/240	3	60	41/51	123	37/46	111
	120/240	1	60	37/37	154	34/34	141
	139/240	3	60	42/52	126	37/46	111
	220/380	3	60	41/51	77	37/46	70
	277/480	3	60	42/52	63	37/46	55
347/600	3	60	42/52	50	37/46	44	
4P7BX	120/208	3	60	42/52	145	37/46	128
	127/220	3	60	42/52	137	37/46	121
	120/240	3	60	41/51	123	37/46	111
	120/240	1	60	40/40	166	36/36	150
	139/240	3	60	42/52	126	37/46	111
	220/380	3	60	42/52	79	37/46	70
	277/480	3	60	42/52	63	37/46	55
347/600	3	60	42/52	50	37/46	44	
4Q5X	120/240	1	60	40/40	166	36/36	150
4Q7BX	120/240	1	60	40/40	166	36/36	150

RATINGS: All three-phase units are rated at 0.8 power factor. All single-phase units are rated at 1.0 power factor. **Standby Ratings:** Standby rating is applicable to varying loads for the duration of a power outage. There is no overload capability for this rating. **Prime Power Ratings:** At varying load, the number of generator set operating hours is unlimited. A 10% overload capacity is available for one hour in twelve. Ratings are in accordance with ISO-8528-1 and ISO-3046-1. For limited running time and continuous ratings, consult the factory. Obtain the technical information bulletin (TIB-101) for ratings guidelines, complete ratings definitions, and site condition derates. The generator set manufacturer reserves the right to change the design or specifications without notice and without any obligation or liability whatsoever.

Alternator Specifications

Specifications	Alternator
Manufacturer	Kohler
Type	4-Pole, Rotating-Field
Exciter type	Brushless, Rare-Earth Permanent Magnet
Leads: quantity, type	12, Reconnectable 4, 110-120/220-240
Voltage regulator	Solid State, Volts/Hz
Insulation:	NEMA MG1
Material	Class H
Temperature rise	130°C, Standby
Bearing: quantity, type	1, Sealed
Coupling	Flexible Disc
Amortisseur windings	Full
Voltage regulation, no-load to full-load	Controller Dependent
One-step load acceptance	100% of Rating
Unbalanced load capability	100% of Rated Standby Current

- NEMA MG1, IEEE, and ANSI standards compliance for temperature rise and motor starting.
- Sustained short-circuit current of up to 300% of the rated current for up to 10 seconds.
- Sustained short-circuit current enabling downstream circuit breakers to trip without collapsing the alternator field.
- Self-ventilated and dripproof construction.
- Windings are vacuum-impregnated with epoxy varnish for dependability and long life.
- Superior voltage waveform from a two-thirds pitch stator and skewed rotor.

Specifications	Alternator
Peak motor starting kVA:	(35% dip for voltages below)
480 V 4P5X (12 lead)	138
480 V 4P7BX (12 lead)	180
240 V 4Q5X (4 lead)	92
240 V 4Q7BX (4 lead)	113

Application Data

Engine

Engine Specifications	
Manufacturer	Kohler Diesel
Engine model	KDI 3404TM
Engine type	4-Cycle, Turbocharged
Cylinder arrangement	4 Inline
Displacement, L (cu. in.)	3.4 (207)
Bore and stroke, mm (in.)	96 x 116 (3.28 x 4.57)
Compression ratio	18.5:1
Piston speed, m/min. (ft./min.)	418 (1371)
Main bearings: quantity, type	5, Replaceable Insert
Rated rpm	1800
Max. power at rated rpm, kWm (BHP)	50 (67)
Cylinder head material	Cast Iron
Crankshaft material	Cast Iron
Valve material:	
Intake	Chromium-Silicon Steel
Exhaust	Chromium Steel
Governor: type, make/model	Stanadyne/Mechanical (or Electronic *)
	Droop, 5% (or Isochronous *)
Frequency regulation, no-load to full-load	±0.5%
Frequency regulation, steady state	Fixed
Frequency	Dry
Air cleaner type, all models	
* Requires available electronic governor option	

Engine Electrical

Engine Electrical System	
Battery charging alternator:	
Ground (negative/positive)	Negative
Volts (DC)	12
Ampere rating	90
Starter motor rated voltage (DC)	12
Battery, recommended cold cranking amps (CCA):	
Quantity, CCA rating	One, 650
Battery voltage (DC)	12

Fuel

Fuel System	
Fuel supply line, min. ID, mm (in.)	8.0 (0.31)
Fuel return line, min. ID, mm (in.)	6.0 (0.25)
Max. lift, engine-driven fuel pump, m (ft.)	3.0 (10.0)
Max. fuel flow, Lph (gph)	46 (12.2)
Max. return line restriction, kPa (in. Hg)	20 (5.9)
Fuel filter	
Prefilter	74 Microns
Primary/Water Separator	5 Microns @ 98% Efficiency
Recommended fuel	#2 Ultra Low Sulfur Diesel

Lubrication

Lubricating System	
Type	Full Pressure
Oil pan capacity, L (qt.)	15.3 (16.2)
Oil pan capacity with filter, L (qt.)	15.6 (16.5)
Oil filter: quantity, type	1, Cartridge
Oil cooler	Water-Cooled

Exhaust

Exhaust System	
Exhaust manifold type	Dry
Exhaust flow at rated kW, m ³ /min. (cfm)	8.1 (286)
Exhaust temperature at rated kW, dry exhaust, °C (°F)	490 (914)
Minimum/maximum allowable back pressure, kPa (in. Hg)	6 (1.8)/9 (2.7)
Exhaust outlet size at engine hookup, mm (in.)	63.5 (2.5)

Application Data

Cooling

Radiator System

Ambient temperature, °C (°F) *	50 (122)
Engine jacket water capacity, L (gal.)	4.5 (1.19)
Radiator system capacity, including engine, L (gal.)	12.3 (3.2)
Engine jacket water flow, Lpm (gpm)	125 (33)
Heat rejected to cooling water at rated kW, dry exhaust, kW (Btu/min.)	32 (1821)
Heat rejected to air charge cooler at rated kW, dry exhaust, kW (Btu/min.)	11 (626)
Water pump type	Centrifugal
Fan diameter, including blades, mm (in.)	597 (23.5)
Fan, kWm (HP)	1.8 (2.3)
Max. restriction of cooling air, intake and discharge side of radiator, kPa (in. H ₂ O)	0.125 (0.5)

* Enclosure reduces ambient temperature capability by 5°C (9°F).

Operation Requirements

Air Requirements

Radiator-cooled cooling air, m ³ /min. (scfm) †	96.3 (3400)
Combustion air, m ³ /min. (cfm)	4.5 (159)
Heat rejected to ambient air:	
Engine, kW (Btu/min.)	10.5 (600)
Alternator, kW (Btu/min.)	7.6 (435)
Max. air intake restriction, kPa (in. Hg)	5.2 (1.54)

† Air density = 1.20 kg/m³ (0.075 lbm/ft³)

Fuel Consumption

Diesel, Lph (gph) at % load	Standby Rating
100%	14.0 (3.7)
75%	11.7 (3.1)
50%	9.1 (2.4)
25%	4.9 (1.3)
Diesel, Lph (gph) at % load	Prime Rating
100%	13.2 (3.5)
75%	10.6 (2.8)
50%	7.6 (2.0)
25%	4.9 (1.3)

Controllers

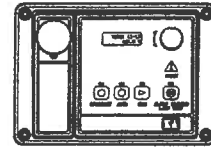

Decision-Maker® 3000 Controller

Provides advanced control, system monitoring, and system diagnostics for optimum performance and compatibility.

- Digital display and menu control provide easy local data access
- Measurements are selectable in metric or English units
- Remote communication thru a PC via network or serial configuration
- Controller supports Modbus® protocol
- Integrated hybrid voltage regulator with ±0.5% regulation
- Built-in alternator thermal overload protection
- NFPA 110 Level 1 capability

Refer to G6-100 for additional controller features and accessories.

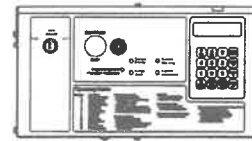

Decision-Maker® 550 Controller

Provides advanced control, system monitoring, and system diagnostics with remote monitoring capabilities.

- Digital display and keypad provide easy local data access
- Measurements are selectable in metric or English units
- Remote communication thru a PC via network or modem configuration
- Controller supports Modbus® protocol
- Integrated voltage regulator with ±0.25% regulation
- Built-in alternator thermal overload protection
- NFPA 110 Level 1 capability

Refer to G6-46 for additional controller features and accessories.

Modbus® is a registered trademark of Schneider Electric.

Additional Standard Features

- Air Cleaner, Heavy Duty
- Alternator Protection
- Battery Rack and Cables
- Open Crankcase Ventilation
- Oil Drain and Coolant Drain with Hose Barb
- Oil Drain Extension (with narrow skid and enclosure models only)
- Operation and Installation Literature
- Radiator Drain Extension (with enclosure models only)
- Stainless Steel Fasteners on Enclosure (with enclosure models only)

Available Options

Approvals and Listings

- CSA Certified
- IBC Seismic Certification
- UL2200 Listing

Enclosed Unit

- Sound Enclosure (with enclosed critical silencer)
- Weather Enclosure (with enclosed critical silencer)
- Stainless Steel Latches and Hinges

Open Unit

- Exhaust Silencer, Critical (kit: PA-324470)
- Flexible Exhaust Connector, Stainless Steel

Fuel System

- Flexible Fuel Lines
- Fuel Pressure Gauge
- Subbase Fuel Tanks

Controller

- Common Failure Relay
- Communication Products and PC Software (550 controller only)
- Customer Connection (550 controller only)
- Dry Contact (isolated alarm) (550 controller only)
- Input/Output Module
- Manual Speed Adjust (requires Electronic Governor or 550 controller)
- Remote Annunciator Panel
- Remote Emergency Stop
- Run Relay

Cooling System

- Block Heater (1000 W, 110–120 V)
Recommended for ambient temperatures below 0°C (32°F).
- Radiator Duct Flange

Electrical System

- Alternator Strip Heater
- Battery
- Battery Charger, Equalize/Float Type
- Battery Heater
- Electronic Governor
- Line Circuit Breaker (NEMA type 1 enclosure)
- Line Circuit Breaker with Shunt Trip (NEMA type 1 enclosure)

Miscellaneous

- Air Cleaner Restriction Indicator
- Engine Fluids Added
- Rated Power Factor Testing
- Rodent Guards

Literature

- General Maintenance
- NFPA 110
- Overhaul
- Production

Warranty

- 2-Year Basic Limited Warranty
- 5-Year Basic Limited Warranty
- 5-Year Comprehensive Limited Warranty

Other Options

- _____
- _____
- _____
- _____
- _____

Dimensions and Weights

Overall Size, L x W x H, mm (in.):

Wide Skid: 2300 x 1040 x 1133 (90.6 x 41.0 x 44.6)

Narrow Skid: 1875 x 780 x 1067 (73.8 x 30.7 x 42.0)

Weight (radiator model), wet, kg (lb.): 787 (1735)

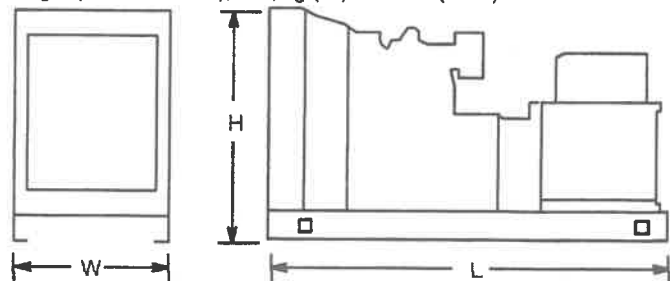

NOTE: This drawing is provided for reference only and should not be used for planning installation. Contact your local distributor for more detailed information.

DISTRIBUTED BY:

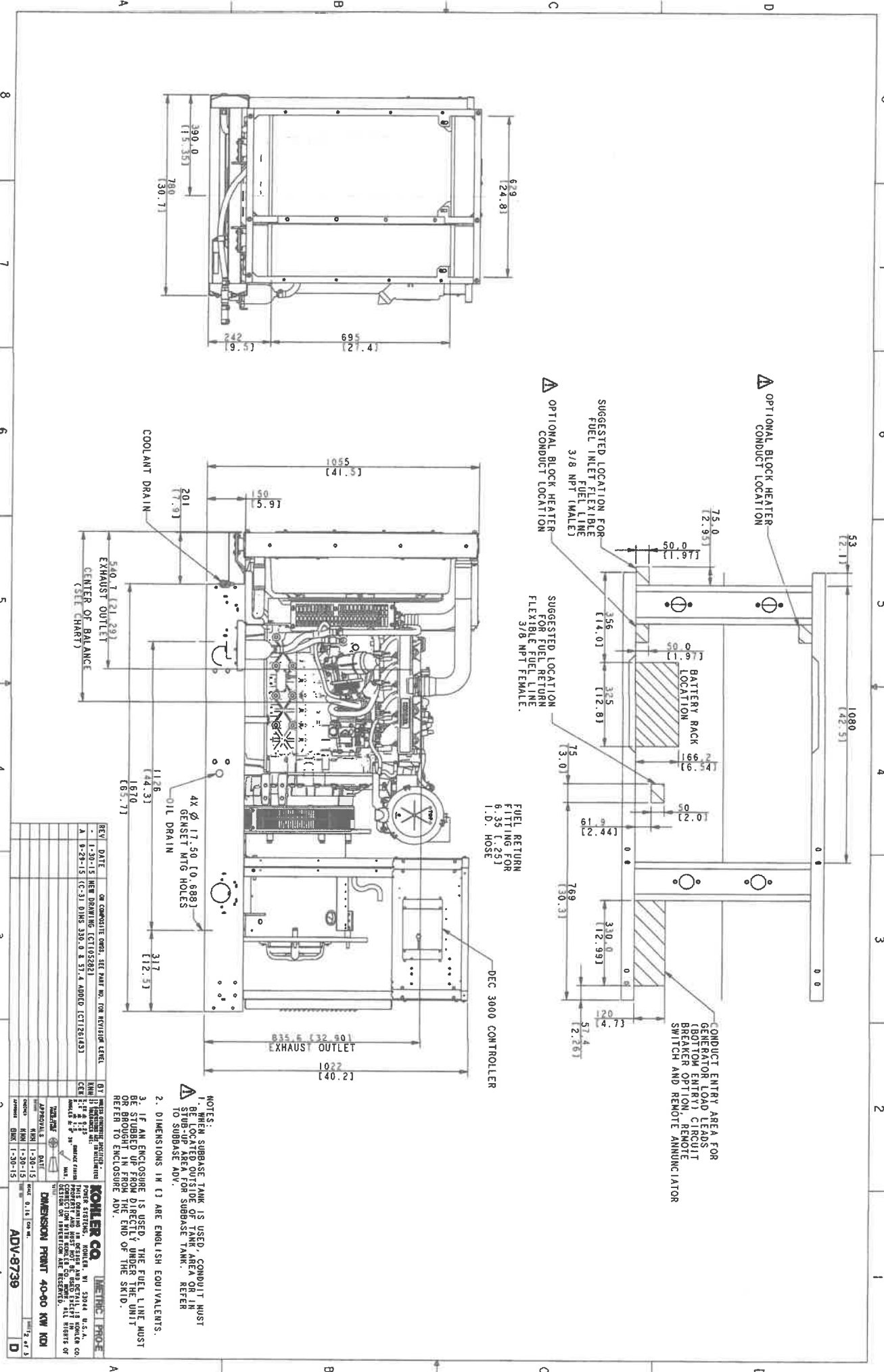

REV	DATE	BY	DESCRIPTION
1	1-30-15	HEB	NEW DRAWING (C1105282)
2	9-29-15	CC-31	CHG DIMS 330.0 & 57.4 ADDED (C1126183)

REV	DATE	BY	DESCRIPTION
1	1-30-15	HEB	NEW DRAWING (C1105282)
2	9-29-15	CC-31	CHG DIMS 330.0 & 57.4 ADDED (C1126183)

REV	DATE	BY	DESCRIPTION
1	1-30-15	HEB	NEW DRAWING (C1105282)
2	9-29-15	CC-31	CHG DIMS 330.0 & 57.4 ADDED (C1126183)

NOTES:
 1. WHEN SUBBASE TANK IS USED, CONDUIT MUST BE CONNECTED OUTSIDE OF TANK AREA OR IN SUBBASE UNDER SUBBASE TANK. REFER NEITHER TO ENCLOSURE ADV.
 2. DIMENSIONS IN () ARE ENGLISH EQUIVALENTS.
 3. IF AN ENCLOSURE IS USED, THE FUEL LINE MUST BE STUBBED UP FROM DIRECTLY UNDER THE UNIT OR BROUGHT IN FROM THE END OF THE SHED.

KOHLER CO. METRIC LINE
 ADV-8739
 DIMENSION PRINT 40-00 KW KDI
 1 of 3

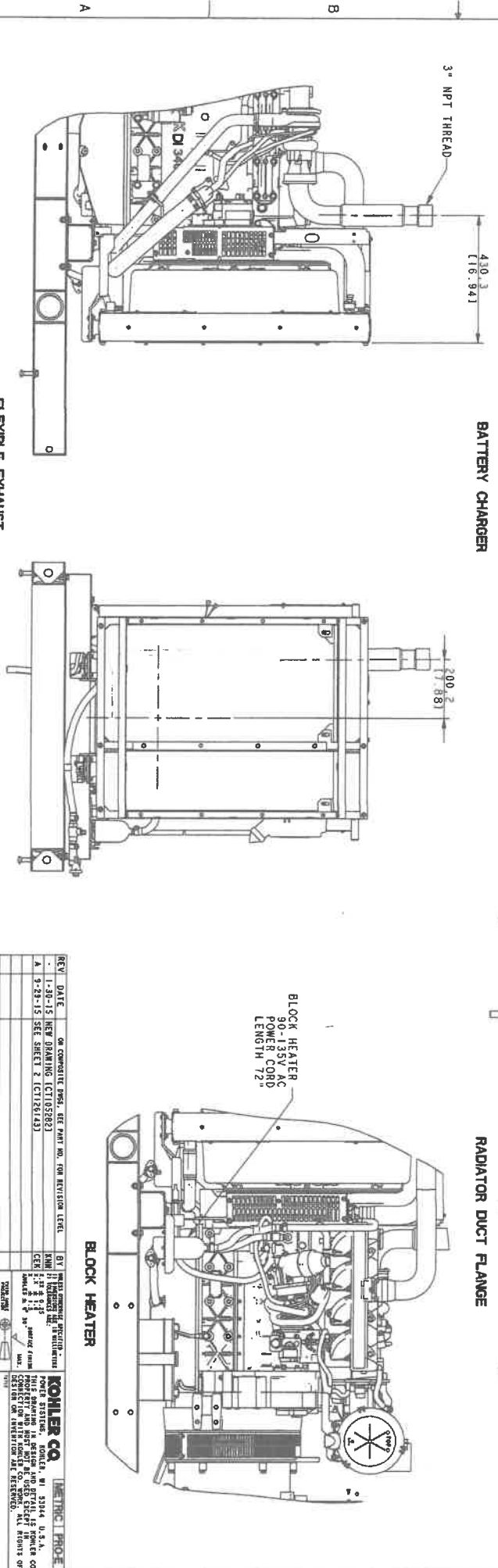
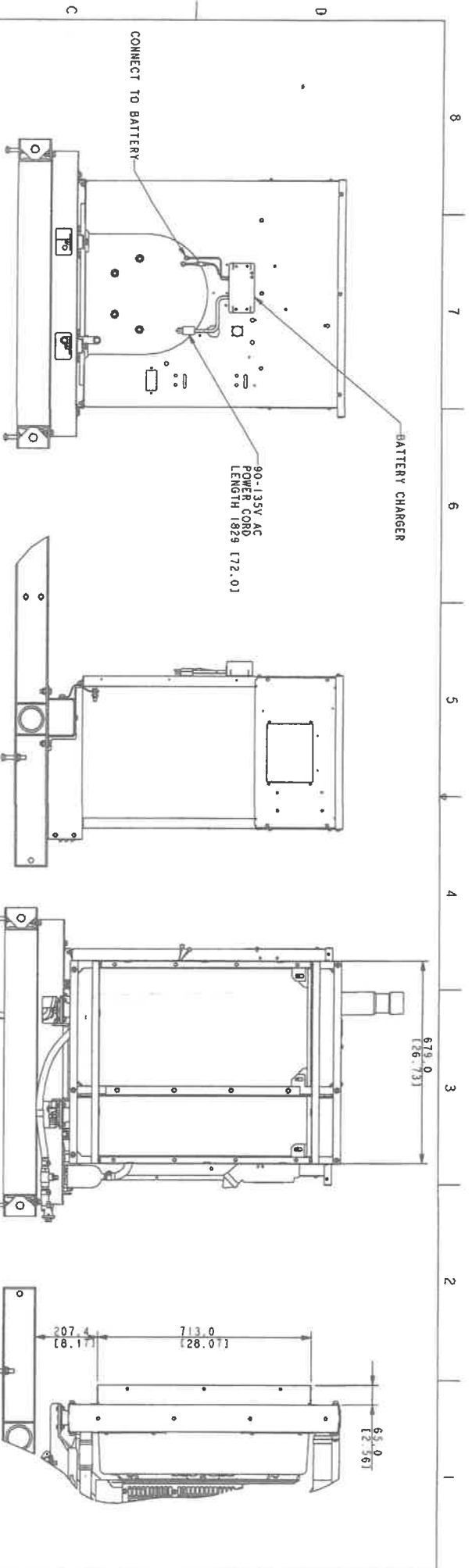

REV	DATE	BY	DESCRIPTION
1	1-30-15	NEW DRAWING	NEW DRAWING [C11052823]
2	3-23-15	SEE SHEET 2	[C11261143]

REV	DATE	BY	DESCRIPTION
1	1-30-15	NEW DRAWING	NEW DRAWING [C11052823]
2	3-23-15	SEE SHEET 2	[C11261143]

REV	DATE	BY	DESCRIPTION
1	1-30-15	NEW DRAWING	NEW DRAWING [C11052823]
2	3-23-15	SEE SHEET 2	[C11261143]

REV	DATE	BY	DESCRIPTION
1	1-30-15	NEW DRAWING	NEW DRAWING [C11052823]
2	3-23-15	SEE SHEET 2	[C11261143]

REV	DATE	BY	DESCRIPTION
1	1-30-15	NEW DRAWING	NEW DRAWING [C11052823]
2	3-23-15	SEE SHEET 2	[C11261143]

REV	DATE	BY	DESCRIPTION
1	1-30-15	NEW DRAWING	NEW DRAWING [C11052823]
2	3-23-15	SEE SHEET 2	[C11261143]

REV	DATE	BY	DESCRIPTION
1	1-30-15	NEW DRAWING	NEW DRAWING [C11052823]
2	3-23-15	SEE SHEET 2	[C11261143]

KOHLER CO. METRIC PROE

THIS DRAWING IS THE PROPERTY OF KOHLER CO. IT IS TO BE USED ONLY FOR THE PURPOSES SPECIFIED HEREIN. NO PART OF THIS DRAWING IS TO BE REPRODUCED OR TRANSMITTED IN ANY FORM OR BY ANY MEANS, ELECTRONIC OR MECHANICAL, INCLUDING PHOTOCOPYING, RECORDING, OR BY ANY INFORMATION STORAGE AND RETRIEVAL SYSTEM, WITHOUT THE WRITTEN PERMISSION OF KOHLER CO.

DIMENSION PRINT 40-80 KW KDI

ADV-8739

Weather/Sound Enclosure and Subbase Fuel Tank

Applicable to the following:
15-60REOZK

Weather Enclosure Standard Features

- Internal-mounted silencer and flexible exhaust connector.
- Lift base or tank-mounted, steel construction with hinged doors on the service side and easily removable panels on the non-service side.
- Fade-, scratch-, and corrosion-resistant Kohler® Power Armor™ automotive-grade textured finish.
- Enclosure has four large access doors/panels which allow for easy maintenance.
- Lockable, flush-mounted door latches.
- Horizontal air inlet and vertical outlet discharge to redirect air and reduce noise.

Sound Enclosure Standard Features

- Includes all of the weather enclosure features with the addition of acoustic insulation material.
- Lift base or tank-mounted, steel or aluminum construction. Aluminum enclosures are recommended for high humidity and/or high salt/ coastal regions.
- Acoustic insulation that meets UL 94 HF1 flammability classification and repels moisture absorption.
- Sound attenuated enclosure that uses up to 51 mm (2 in.) of acoustic insulation.
- Aluminum sound enclosure is certified to 186 mph (299 kph) wind load rating.

Subbase Fuel Tank Features

- The fuel tank has a Power Armor Plus™ textured epoxy-based rubberized coating.
- The above-ground rectangular secondary containment tank mounts directly to the generator set, below the generator set skid (subbase).
- Both the inner and outer tanks have emergency relief vents.
- Flexible fuel lines are provided with subbase fuel tank selection.
- The secondary containment generator set base tank meets UL 142 tank requirements. The inner (primary) tank is sealed inside the outer (secondary) tank. The outer tank contains the fuel if the inner tank leaks or ruptures.
- State tanks with varying capacities are an available option. Florida Dept. of Environmental Protection (FDEP) File No. EQ-634 approved.

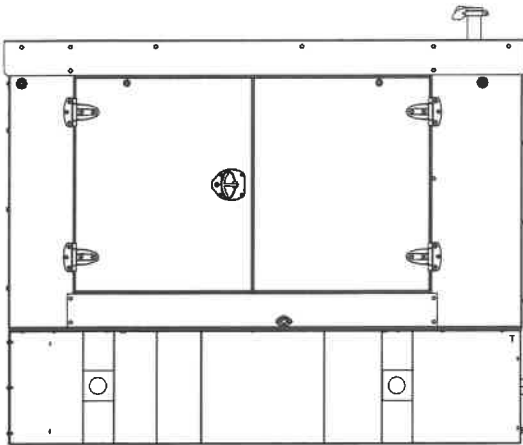

Enclosure with Standard Subbase Fuel Tank

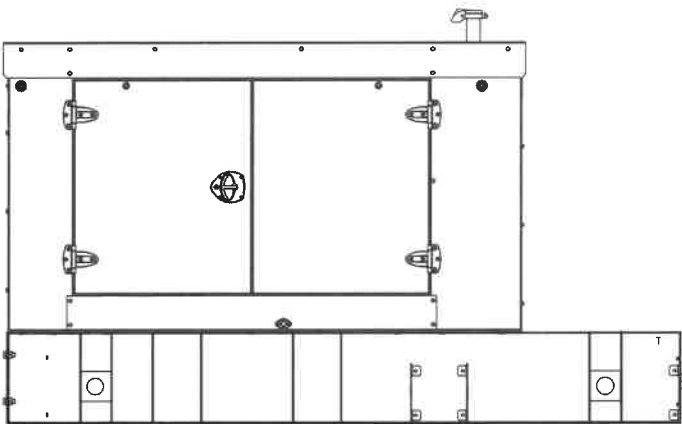

Enclosure with State Code Subbase Fuel Tank

Available Approvals and Listings

- UL 2200 Listing
- CSA Certified
- IBC Seismic Certification
- cUL Listing (fuel tanks only)

NOTE: Some models may have limited third-party approvals; see your local distributor for details.

Weather and Sound Enclosure

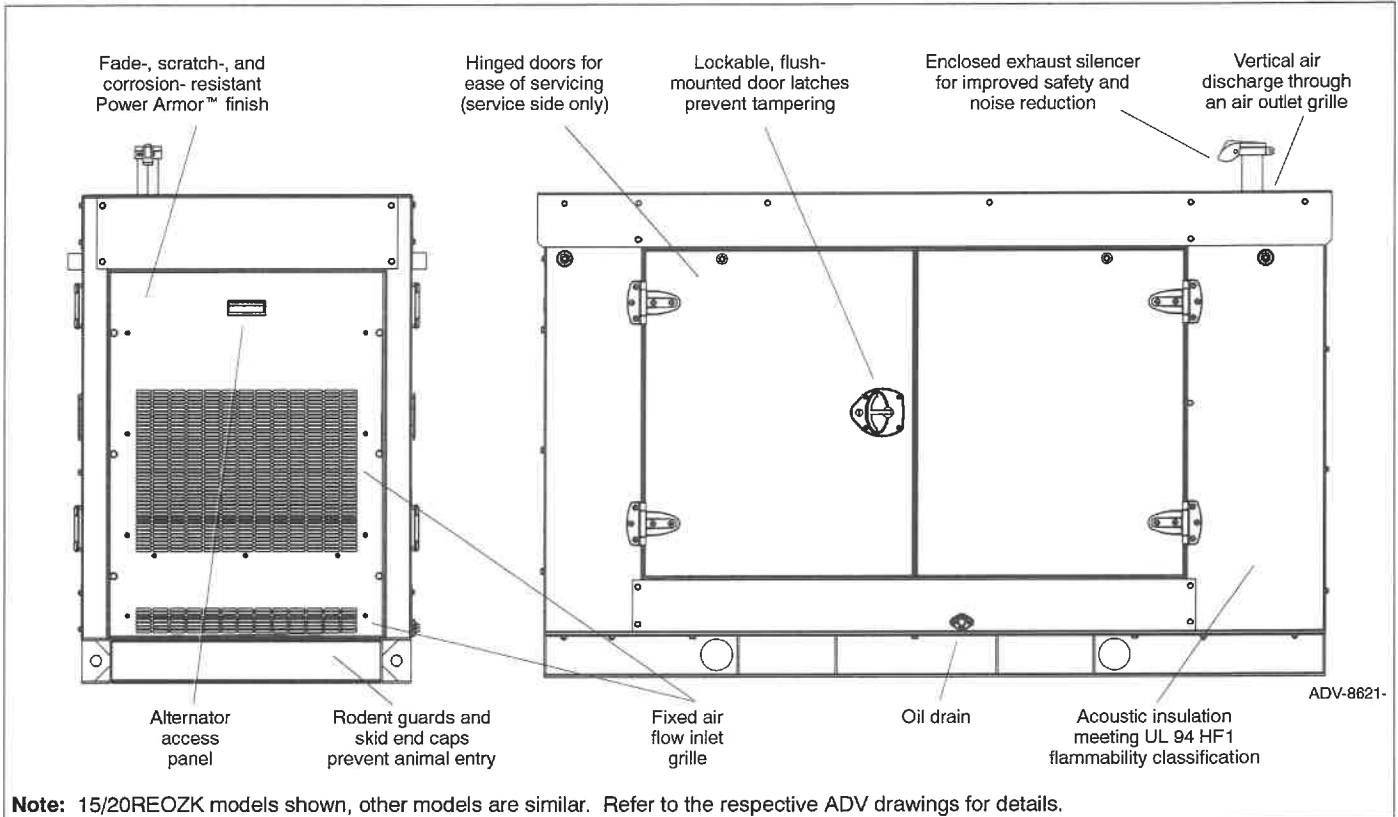

Enclosure Features

- Available in steel (18 gauge) formed panel, solid construction. Preassembled package offering corrosion resistant, dent resilient structure mounting directly to lift base or fuel tank.
 - Power Armor™ automotive-grade finish resulting in advanced corrosion and abrasion protection as well as enhanced edge coverage and color retention.
 - Internal exhaust silencer offering maximum component life and operator safety.
 - Interchangeable modular panel construction. Allows complete serviceability or replacement without compromising enclosure design.
 - Cooling/combustion air intake with a horizontal air inlet. Sized for maximum cooling airflow.
 - Service access. Multi-personnel doors/panels for easy access to generator set control and servicing of the fuel fill, fuel gauge, oil fill, and battery.
 - Cooling air discharge. Weather protective design featuring a vertical air discharge outlet grille. Redirects cooling air up and above enclosure to reduce ambient noise.
- NOTE:** Installing an additional length of exhaust tail pipe may increase backpressure levels. Please refer to the generator set spec sheet for the maximum backpressure value.

Additional Sound Enclosure Features

- Available in steel (18 gauge) or aluminum 2 mm (0.08 in.) formed panel, solid construction.
- Attenuated design. Acoustic insulation UL 94 HF1 listed for flame resistance offering up to 51 mm (2 in.) mechanically restrained acoustic insulation.
- Cooling air discharge. The sound enclosures include acoustic insulation with urethane film.

Subbase Fuel Tank

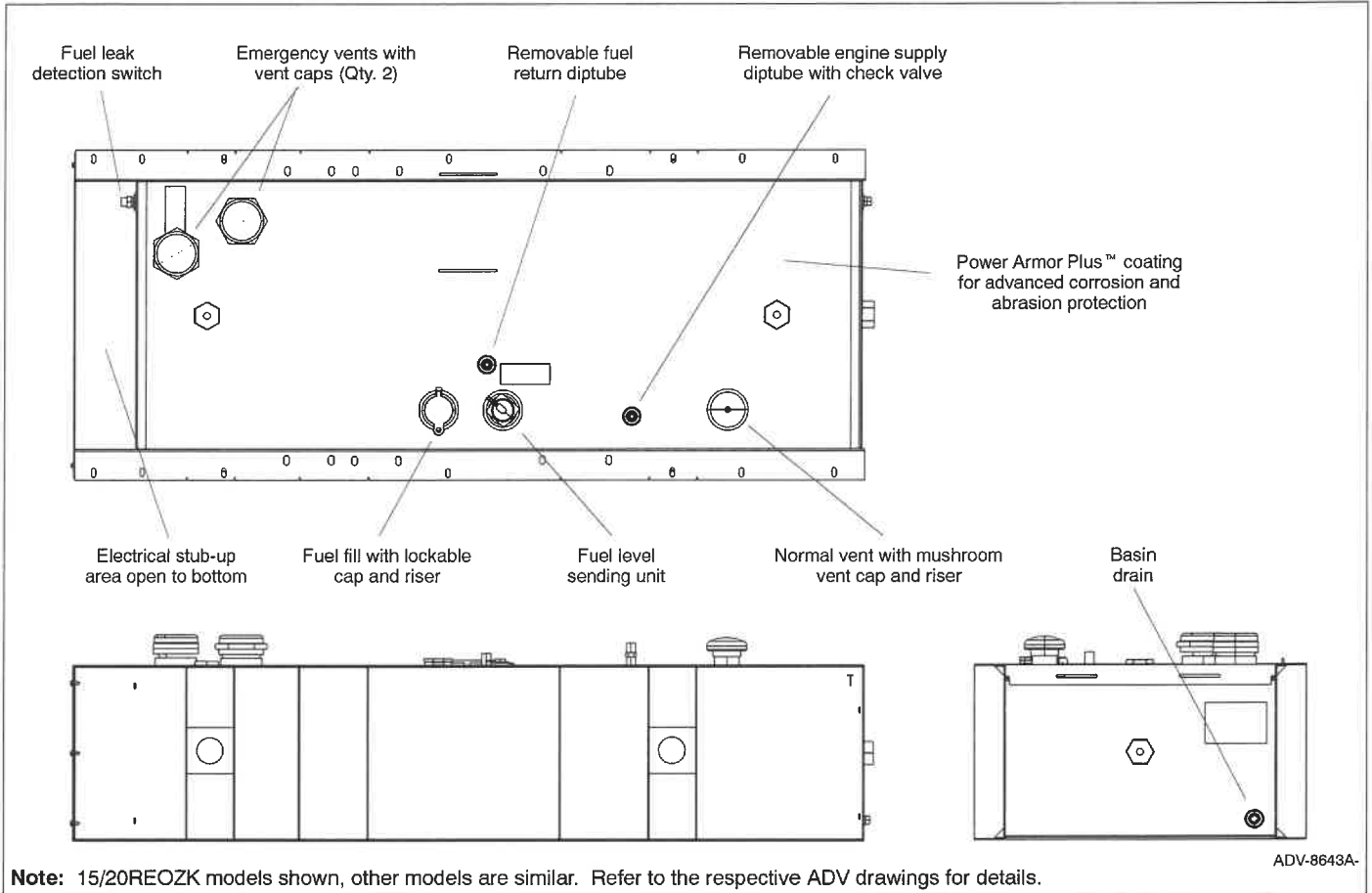

Standard Subbase Fuel Tank Features

- Extended operation. Usable tank capacity offers full load standby operation of up to 72 hours.
- Power Armor Plus™ textured epoxy-based rubberized coating that creates an ultra-thick barrier between the tank and harsh environmental conditions like humidity, saltwater, and extreme temperatures, and provides advanced corrosion and abrasion protection.
- UL listed. Secondary containment generator set base tank meeting UL 142 requirements.
- NFPA compliant. Designed to comply with the installation standards of NFPA 30 and NFPA 37.
- Integral external lift lugs. Enables crane with spreader-bar lifting of the complete package (empty tank, mounted generator set, and enclosure) to ensure safety.
- Emergency pressure relief vents. Vents ensure adequate venting of the inner and outer tank under extreme pressure and/or emergency conditions.
- Normal vent with cap and riser.
- Leak detection switch. Annunciates a contained primary tank fuel leak condition at the generator set control.
- Electrical stub-up.

State Code Subbase Fuel Tank Features

- State tank designed to comply with the installation standards of the Florida Dept. of Environmental Protection (FDEP) File No. EQ-634.
- Includes all of the Standard Subbase Fuel Tank Features.
- Usable tank capacity offers full load standby operation of up to 96 hours.

State Code Subbase Fuel Tank

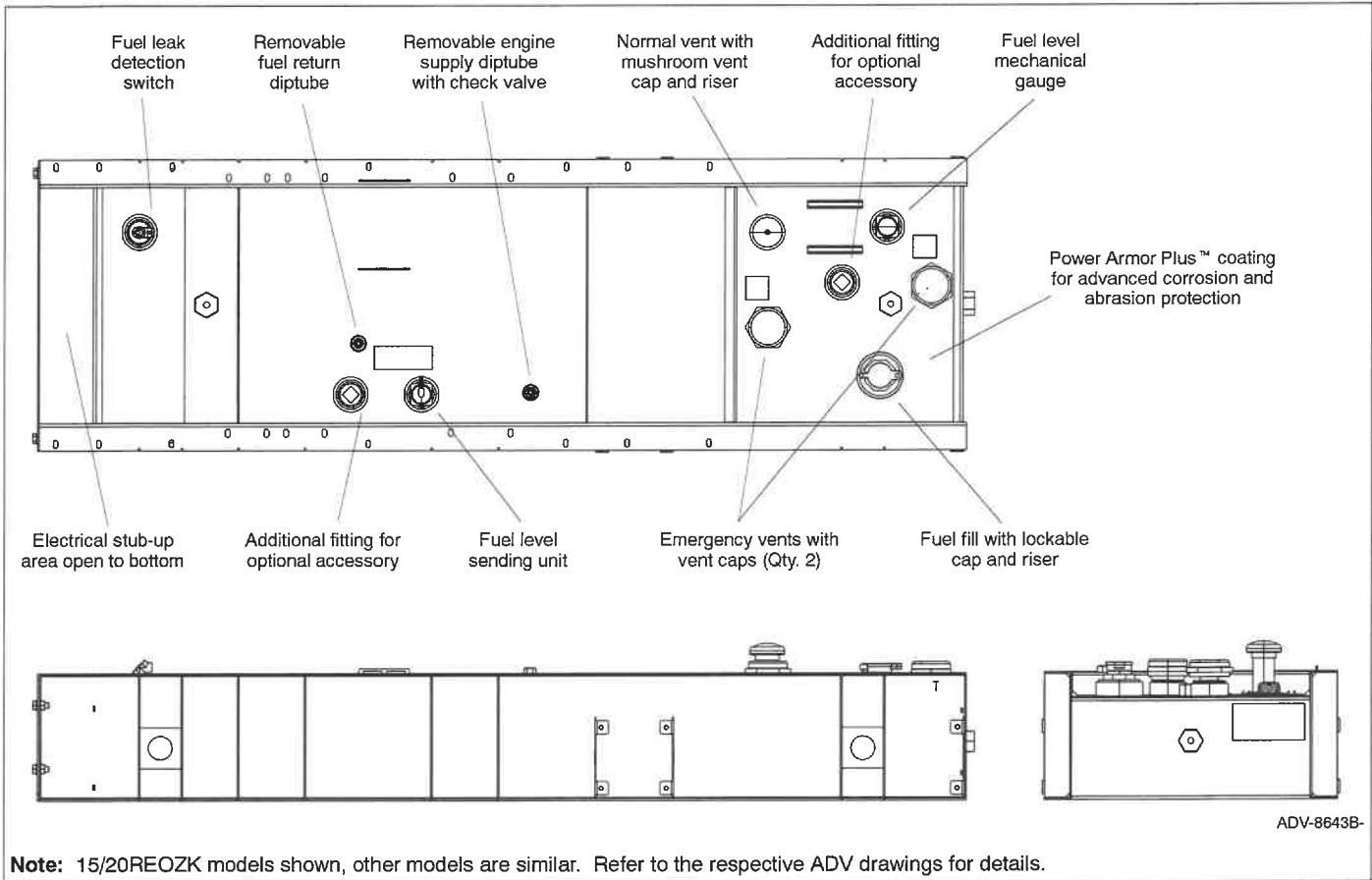

State Code Subbase Fuel Tank Options

Bottom Clearance

- I-beams, provides 102 mm (4 in.) of ground clearance

Fuel in Basin Options

- Fuel in basin switch, Florida Dept. of Environmental Protection (FDEP) File No. EQ-682 approved

Fuel Fill Options

- Fill pipe extension to within 152 mm (6 in.) of bottom of fuel tank.
- 18.9 L (5 gallon) spill containment with 95% shutoff
- 18.9 L (5 gallon) spill containment
- 18.9 L (5 gallon) spill containment fill to within 152 mm (6 in.) of bottom of fuel tank
- 28.4 L (7.5 gallon) spill containment, Florida Dept. of Environmental Protection (FDEP) File No. EQ-345 approved
- 28.4 L (7.5 gallon) spill containment with 95% shutoff, Florida Dept. of Environmental Protection (FDEP) File No. EQ-345/ EQ-257 approved

Fuel Supply Options

- Fire safety valve (installed on fuel supply line)
- Ball valve (installed on fuel supply line)

High Fuel Level Switch

- High fuel level switch
- High fuel level switch, Florida Dept. of Environmental Protection (FDEP) File No. EQ-682 approved

Normal Vent Options

- 3.7 m (12 ft.) above grade (without spill containment)
- 3.7 m (12 ft.) above grade (with spill containment)

Tank Marking Options

- Decal, Combustible Liquids - Keep Fire Away (qty. 2)
- Decal, NFPA 704 identification (qty. 2)
- Decal, tank number and safe fuel fill height (qty. 2)
- Decal, tank number and safe fuel fill height, NFPA 704 identification

Fluid Containment Options

- 100% engine fluid containment

Weather Enclosure and Subbase Fuel Tank Specifications

Fuel Tank Capacity, L (gal.)	Est. Fuel Supply Hours at 60 Hz with Full Load, Nominal/Actual	Enclosure and Subbase Fuel Tank					Fuel Tank Height, mm (in.)	Sound Pressure Level at 60 Hz with Full Load, dB(A) §
		Max. Dimensions, mm (in.)			Max. Weight, kg (lb.) *			
		Length	Width ‡	Height	With Steel Enclosure	With Aluminum Enclosure		
15REOZK								
No Tank	0	1969 (77.5)	882 (34.7)	1327 (52.3)	585 (1290)	not available	0 (0)	77
301 (80)	48/53			1649 (64.9)	793 (1749)		432 (17)	
465 (123)	72/82			1852 (72.9)	851 (1876)		635 (25)	
15REOZK with IBC Seismic Certification and State Code Fuel Tank †								
330 (87)	48/58	2575 (101.4)	882 (34.7)	1573 (61.9)	932 (2055)	not available	356 (14)	77
476 (126)	72/84			1700 (66.9)	996 (2196)		483 (19)	
638 (168)	96/112			1827 (71.9)	1064 (2345)		610 (24)	
20REOZK								
No Tank	0	1969 (77.5)	882 (34.7)	1327 (52.3)	621 (1370)	not available	0 (0)	79
301 (80)	24/38			1649 (64.9)	829 (1829)		432 (17)	
465 (123)	48/58			1852 (72.9)	887 (1956)		635 (25)	
622 (164)	72/78			2030 (79.9)	936 (2065)		813 (32)	
20REOZK with IBC Seismic Certification and State Code Fuel Tank †								
330 (87)	24/41	2575 (101.4)	882 (34.7)	1573 (61.9)	968 (2135)	not available	356 (14)	79
476 (126)	48/60			1700 (66.9)	1032 (2276)		483 (19)	
638 (168)	72/80			1827 (71.9)	1100 (2425)		610 (24)	
838 (221)	96/105			1979 (77.9)	1181 (2605)		762 (30)	
30REOZK								
No Tank	0	1969 (77.5)	882 (34.7)	1327 (52.3)	680 (1500)	not available	0 (0)	79
301 (80)	24/30			1759 (69.3)	888 (1959)		432 (17)	
622 (164)	48/63			2140 (84.3)	995 (2195)		813 (32)	
791 (209)	72/80			2070 (81.5)	2241 (88.3)		1042 (2298)	
30REOZK with IBC Seismic Certification and State Code Fuel Tank †								
330 (87)	24/33	2575 (101.4)	882 (34.7)	1573 (61.9)	1027 (2265)	not available	356 (14)	79
638 (168)	48/64			1827 (71.9)	1159 (2555)		610 (24)	
838 (221)	72/85			1979 (77.9)	1240 (2735)		762 (30)	
1056 (279)	96/107			2241 (88.3)	1323 (2919)		914 (36)	
40REOZK								
No Tank	0	2320 (91.3)	1070 (42.1)	1465 (57.7)	1048 (2310)	not available	0 (0)	79
505 (133)	24/36			1838 (72.4)	1328 (2928)		483 (19)	
868 (229)	48/62			2142 (84.4)	1427 (3146)		787 (31)	
1043 (275)	72/74			2244 (88.4)	1464 (3228)		889 (35)	
40REOZK with IBC Seismic Certification and State Code Fuel Tank †								
541 (142)	24/38	2896 (114.0)	1070 (42.1)	1787 (70.4)	1514 (3337)	not available	432 (17)	79
898 (237)	48/64			2015 (79.4)	1647 (3631)		660 (26)	
1057 (279)	72/75			2117 (83.4)	1706 (3762)		762 (30)	
1520 (401)	96/108			2269 (89.4)	1825 (4024)		914 (36)	
50REOZK								
No Tank	0	2320 (91.3)	1070 (42.1)	1465 (57.7)	1063 (2344)	not available	0 (0)	79
505 (133)	24/29			1838 (72.4)	1343 (2962)		483 (19)	
868 (229)	48/50			2142 (84.4)	1442 (3180)		787 (31)	
1527 (403)	72/88			2896 (114.0)	2269 (89.4)		1585 (3496)	
50REOZK with IBC Seismic Certification and State Code Fuel Tank †								
541 (142)	24/31	2896 (114.0)	1070 (42.1)	1787 (70.4)	1529 (3371)	not available	432 (17)	79
898 (237)	48/52			2015 (79.4)	1662 (3665)		660 (26)	
1520 (401)	72/87			2269 (89.4)	1840 (4058)		914 (36)	
2028 (535)	96/116			4020 (158.3)	2041 (4500)			

Weather Enclosure and Subbase Fuel Tank Specifications (continued)

Fuel Tank Capacity, L (gal.)	Est. Fuel Supply Hours at 60 Hz with Full Load, Nominal/Actual	Enclosure and Subbase Fuel Tank					Fuel Tank Height, mm (in.)	Sound Pressure Level at 60 Hz with Full Load, dB(A) §
		Max. Dimensions, mm (in.)			Max. Weight, kg (lb.) *			
		Length	Width ‡	Height	With Steel Enclosure	With Aluminum Enclosure		
60REOZK								
No Tank	0	2320 (91.3)	1070 (42.1)	1465 (57.7)	1102 (2430)	not available	0 (0)	80
505 (133)	24/25			1838 (72.4)	1382 (3048)		483 (19)	
1043 (275)	48/51			2244 (88.4)	1518 (3348)		889 (35)	
1527 (403)	72/75			2896 (114.0)	1624 (3582)		914 (36)	
60REOZK with IBC Seismic Certification and State Code Fuel Tank †								
541 (142)	24/26	2896 (114.0)	1070 (42.1)	1787 (70.4)	1568 (3457)	not available	432 (17)	80
1057 (279)	48/52			2117 (83.4)	1733 (3882)		762 (30)	
1520 (401)	72/74			2269 (89.4)	1852 (4144)		914 (36)	
2028 (535)	96/99			4020 (158.3)	2053 (4586)			

Note: Data in table is for reference only, refer to the respective ADV drawings for details.

* Max. weight includes the generator set (wet) using the largest alternator option, enclosure with acoustic insulation added, silencer, and tank (no fuel).

† State code fuel tank specifications (height and weight) do not include I-beam option.

‡ Width dimension shown includes rubber door stops.

§ Log average sound pressure level of 8 measured positions around the perimeter of the unit at a distance of 7 m (23 ft). Refer to TIB-114 for details.

Sound Enclosure and Subbase Fuel Tank Specifications

Fuel Tank Capacity, L (gal.)	Est. Fuel Supply Hours at 60 Hz with Full Load, Nominal/Actual	Enclosure and Subbase Fuel Tank					Fuel Tank Height, mm (in.)	Sound Pressure Level at 60 Hz with Full Load, dB(A) §
		Max. Dimensions, mm (in.)			Max. Weight, kg (lb.) *			
		Length	Width ‡	Height	With Steel Enclosure	With Aluminum Enclosure		
15REOZK								
No Tank	0	1969 (77.5)	882 (34.7)	1327 (52.3)	594 (1310)	530 (1168)	0 (0)	64
301 (80)	48/53			1649 (64.9)	802 (1769)	738 (1627)	432 (17)	
465 (123)	72/82			1852 (72.9)	860 (1896)	796 (1754)	635 (25)	
15REOZK with IBC Seismic Certification and State Code Fuel Tank †								
330 (87)	48/58	2575 (101.4)	882 (34.7)	1573 (61.9)	941 (2075)	877 (1933)	356 (14)	64
476 (126)	72/84			1700 (66.9)	1005 (2216)	941 (2074)	483 (19)	
638 (168)	96/112			1827 (71.9)	1073 (2365)	1009 (2223)	610 (24)	
20REOZK								
No Tank	0	1969 (77.5)	882 (34.7)	1327 (52.3)	630 (1390)	566 (1248)	0 (0)	65
301 (80)	24/38			1649 (64.9)	838 (1849)	774 (1707)	432 (17)	
465 (123)	48/58			1852 (72.9)	896 (1976)	832 (1834)	635 (25)	
622 (164)	72/78			2030 (79.9)	945 (2085)	881 (1943)	813 (32)	
20REOZK with IBC Seismic Certification and State Code Fuel Tank †								
330 (87)	24/41	2575 (101.4)	882 (34.7)	1573 (61.9)	977 (2155)	913 (2013)	356 (14)	65
476 (126)	48/60			1700 (66.9)	1041 (2296)	977 (2154)	483 (19)	
638 (168)	72/80			1827 (71.9)	1109 (2445)	1045 (2303)	610 (24)	
838 (221)	96/105			1979 (77.9)	1190 (2625)	1126 (2483)	762 (30)	
30REOZK								
No Tank	0	1969 (77.5)	882 (34.7)	1327 (52.3)	689 (1520)	624 (1378)	0 (0)	65
301 (80)	24/30			1759 (69.3)	897 (1979)	832 (1837)	432 (17)	
622 (164)	48/63			2140 (84.3)	1004 (2215)	939 (2073)	813 (32)	
791 (209)	72/80			2070 (81.5)	2241 (88.3)	1051 (2318)	986 (2176)	
30REOZK with IBC Seismic Certification and State Code Fuel Tank †								
330 (87)	24/33	2575 (101.4)	882 (34.7)	1573 (61.9)	1036 (2285)	971 (2143)	356 (14)	65
638 (168)	48/64			1827 (71.9)	1168 (2575)	1103 (2433)	610 (24)	
838 (221)	72/85			1979 (77.9)	1249 (2755)	1184 (2613)	762 (30)	
1056 (279)	96/107			2241 (88.3)	1332 (2939)	1267 (2797)	914 (36)	
40REOZK								
No Tank	0	2320 (91.3)	1070 (42.1)	1465 (57.7)	1059 (2335)	957 (2110)	0 (0)	64
505 (133)	24/36			1838 (72.4)	1339 (2953)	1237 (2728)	483 (19)	
868 (229)	48/62			2142 (84.4)	1438 (3171)	1336 (2946)	787 (31)	
1043 (275)	72/74			2244 (89.4)	1475 (3253)	1373 (3028)	889 (35)	

Sound Enclosure and Subbase Fuel Tank Specifications (continued)

Fuel Tank Capacity, L (gal.)	Est. Fuel Supply Hours at 60 Hz with Full Load, Nominal/Actual	Enclosure and Subbase Fuel Tank					Fuel Tank Height, mm (in.)	Sound Pressure Level at 60 Hz with Full Load, dB(A) §
		Max. Dimensions, mm (in.)			Max. Weight, kg (lb.) *			
		Length	Width ‡	Height	With Steel Enclosure	With Aluminum Enclosure		
40REOZK with IBC Seismic Certification and State Code Fuel Tank †								
541 (142)	24/38	2896 (114.0)	1070 (42.1)	1787 (70.4)	1525 (3362)	1423 (3137)	432 (17)	64
898 (237)	48/64			2015 (79.4)	1658 (3656)	1556 (3431)	660 (26)	
1057 (279)	72/75			2137 (83.4)	1717 (3787)	1615 (3562)	782 (30)	
1520 (401)	96/108			2269 (89.4)	1836 (4049)	1734 (3824)	914 (36)	
50REOZK								
No Tank	0	2320 (91.3)	1070 (42.1)	1465 (57.7)	1074 (2369)	972 (2144)	0 (0)	64
505 (133)	24/29			1838 (72.4)	1354 (2987)	1252 (2762)	483 (19)	
868 (229)	48/50			2142 (84.4)	1453 (3205)	1351 (2980)	787 (31)	
1527 (403)	72/88			2269 (89.4)	1596 (3521)	1494 (3296)	914 (36)	
50REOZK with IBC Seismic Certification and State Code Fuel Tank †								
541 (142)	24/31	2896 (114.0)	1070 (42.1)	1787 (70.4)	1540 (3396)	1438 (3171)	432 (17)	64
898 (237)	48/52			2015 (79.4)	1673 (3690)	1571 (3465)	660 (26)	
1520 (401)	72/87			2269 (89.4)	1851 (4083)	1749 (3858)	914 (36)	
2028 (535)	96/116			4020 (158.3)	2052 (4525)	1950 (4300)		
60REOZK								
No Tank	0	2320 (91.3)	1070 (42.1)	1465 (57.7)	1113 (2455)	1011 (2230)	0 (0)	65
505 (133)	24/25			1838 (72.4)	1393 (3073)	1291 (2848)	483 (19)	
1043 (275)	48/51			2244 (88.4)	1529 (3373)	1427 (3148)	889 (35)	
1527 (403)	72/75			2269 (89.4)	1635 (3607)	1533 (3382)	914 (36)	
60REOZK with IBC Seismic Certification and State Code Fuel Tank †								
541 (142)	24/26	2896 (114.0)	1070 (42.1)	1787 (70.4)	1579 (3482)	1453 (3205)	432 (17)	65
1057 (279)	48/52			2117 (83.4)	1771 (3907)	1669 (3682)	762 (30)	
1520 (401)	72/74			2269 (89.4)	1890 (4169)	1788 (3944)	914 (36)	
2028 (535)	96/99			4020 (158.3)	2091 (4611)	1989 (4386)		

Note: Data in table is for reference only, refer to the respective ADV drawings for details.

* Max. weight includes the generator set (wet) using the largest alternator option, enclosure with acoustic insulation added, silencer, and tank (no fuel).

† State code fuel tank specifications (height and weight) do not include I-beam option.

‡ Width dimension shown includes rubber door stops.

§ Log average sound pressure level of 8 measured positions around the perimeter of the unit at a distance of 7 m (23 ft). Refer to TIB-114 for details.

Subbase Fuel Tank Specifications (No Enclosure)

Fuel Tank Capacity, L (gal.)	Est. Fuel Supply Hours at 60 Hz with Full Load, Nominal/Actual	Subbase Fuel Tank *			
		Max. Dimensions, mm (in.)			Max. Weight, kg (lb.)
		Length	Width	Height	
15REOZK					
301 (80)	48/53	1935 (76.2)	810 (31.9)	432 (17)	208 (459)
465 (123)	72/82			635 (25)	266 (586)
15REOZK with IBC Seismic Certification and State Code Fuel Tank †					
330 (87)	48/58	2575 (101.4)	810 (31.9)	356 (14)	347 (765)
476 (126)	72/84			483 (19)	411 (906)
638 (168)	96/112			610 (24)	479 (1055)
20REOZK					
301 (80)	24/38	1935 (76.2)	810 (31.9)	432 (17)	208 (459)
465 (123)	48/58			635 (25)	266 (586)
622 (164)	72/78			813 (32)	315 (695)
20REOZK with IBC Seismic Certification and State Code Fuel Tank †					
330 (87)	24/41	2575 (101.4)	810 (31.9)	356 (14)	347 (765)
476 (126)	48/60			483 (19)	411 (906)
638 (168)	72/80			610 (24)	479 (1055)
838 (221)	96/105			762 (30)	560 (1235)

Subbase Fuel Tank Specifications (No Enclosure) (continued)

Fuel Tank Capacity, L (gal.)	Est. Fuel Supply Hours at 60 Hz with Full Load, Nominal/Actual	Subbase Fuel Tank *			
		Max. Dimensions, mm (in.)			Max. Weight, kg (lb.)
		Length	Width	Height	
30REOZK					
301 (80)	24/30	1935 (76.2)	810 (31.9)	432 (17)	208 (459)
622 (164)	48/63			813 (32)	315 (695)
791 (209)	72/80			914 (36)	362 (798)
30REOZK with IBC Seismic Certification and State Code Fuel Tank †					
330 (87)	24/33	2575 (101.4)	810 (31.9)	356 (14)	347 (765)
638 (168)	48/64			610 (24)	479 (1055)
838 (221)	72/85			762 (30)	560 (1235)
1056 (279)	96/107			914 (36)	643 (1419)
40REOZK					
505 (133)	24/36	2300 (90.6)	1040 (40.9)	483 (19)	280 (618)
868 (229)	48/62			787 (31)	379 (836)
1043 (275)	72/74			889 (35)	416 (918)
40REOZK with IBC Seismic Certification and State Code Fuel Tank †					
541 (142)	24/38	2896 (114.0)	1040 (40.9)	432 (17)	466 (1027)
898 (237)	48/64			660 (26)	599 (1321)
1057 (279)	72/75			762 (30)	658 (1452)
1520 (401)	96/108			914 (36)	777 (1714)
50REOZK					
505 (133)	24/29	2300 (90.6)	1040 (40.9)	483 (19)	280 (618)
868 (229)	48/50			787 (31)	379 (836)
1527 (403)	72/88			2896 (114.0)	914 (36)
50REOZK with IBC Seismic Certification and State Code Fuel Tank †					
541 (142)	24/31	2896 (114.0)	1040 (40.9)	432 (17)	466 (1027)
898 (237)	48/52			660 (26)	599 (1321)
1520 (401)	72/87			914 (36)	777 (1714)
2028 (535)	96/116			4020 (158.0)	978 (2156)
60REOZK					
505 (133)	24/25	2300 (90.6)	1040 (40.9)	483 (19)	280 (618)
1043 (275)	48/51			889 (35)	416 (918)
1527 (403)	72/75			2896 (114.0)	914 (36)
60REOZK with IBC Seismic Certification and State Code Fuel Tank †					
541 (142)	24/26	2896 (114.0)	1040 (40.9)	432 (17)	466 (1027)
1057 (279)	48/52			762 (30)	658 (1452)
1520 (401)	72/74			914 (36)	777 (1714)
2028 (535)	96/99			4020 (158)	978 (2156)

Note: Data in table is for reference only, refer to the respective ADV drawings for details.

* Max. weight includes the tank (no fuel). Height does not include connections/fittings above the tank.

† State code fuel tank specifications (height and weight) do not include I-beam option.

DISTRIBUTED BY:

Town of Ponce Inlet RFP Form

Fire Station Generator

REQUEST FOR PROPOSAL (RFP)

Scope of Work:

The Town of Ponce Inlet is requesting a proposal for an emergency generator for the Fire Station located at 4680 South Peninsula Drive, Ponce Inlet Florida 32127. Proposals shall be submitted based on the purchase, installation, and integration of a 40Kw standby generator. The 40Kw generator can be either diesel or propane powered.

The Generator will be protected against a 500-year flood event or 7 feet above sea level by implementing specific activities or by locating the generator outside the Special Flood Hazard Area (SFHA) and will be protected against wind with a rated enclosure based on its location requirements. Activities will be completed in strict compliance with Federal, State and Local Rules and Regulations.

The Generator shall be designed/constructed/installed in accordance with the International Code Council's ICC/NSSA Standard for the Design and Construction of Storm Shelters (ICC 500-2014) or, where hurricane provisions are more stringent, NFPA 70E 2020, the 2023 Florida Building Code, 8th Edition (Risk Category IV Buildings).

The contractor will be responsible for the permit and engineering to install and integrate the generator to Public Works. After completion of the integration of the generator the contractor will provide a one-hour training session about the generator to Public Works staff.

Deadline:

Please return this Request for Proposal Form addressed to Town Clerk, Town of Ponce Inlet, 4300 S. Atlantic Avenue, Ponce Inlet, FL 32127 in a SEALED ENVELOPE plainly marked on the outside "RFP 2024-05 Fire Station Generator" with a Lump Sum Price by with a Lump Sum Price by 2:00 pm, Monday December 30, 2024.

Scope of Work:

Lump Sum/Unit Pricing:

Table with 5 columns: ITEM NO., DESCRIPTION, EST QUANTITY, UNIT, AMOUNT PROPOSAL. Row 1: 1, 40Kw Generator Project, 1, LS, 78,000.00. LUMP SUM TOTAL: 78,000.00

NOTE: This is for LUMP SUM COST of the entire project, unit prices are to establish pricing if additional work is required above or beyond the Lump Sum Base Price.

Vendor Name: DDS Enterprises LLC, Date: 12/30/24, Company: DDS Enterprises LLC, Phone #: 386-490-5631, eMail: DDSEnterprisesLLC@yahoo.com, Signature: [Handwritten Signature], Print Name: Nick Shephard

NON-COLLUSION AFFIDAVIT

I, Nicholas M. Shephard, depose and say that:

- 1. I am VP of the firm DOS (Interprios) LLC, the firm submitting the response described in this Request for Proposals; and that I executed the said response with full authority to do so;
- 2. The prices in this bid have been arrived at independently without collusion, consultation, communication, or agreement for the purpose of restricting competition, as to any matter relating to such prices with any other bidder or with any competitor;
- 3. Unless otherwise required by law, the prices which have been quoted in this bid have not been knowingly disclosed by the bidder and will not knowingly be disclosed by the bidder prior to bid opening, directly or indirectly, to any other bidder or to any competitor;
- 4. No attempt has been made or will be made by the bidder to induce any other person, partnership, or corporation to submit, or not to submit, a bid for the purpose of restricting competition; and
- 5. The statements contained in this affidavit are true and correct, and made with full knowledge that the Town of Ponce Inlet relies upon the truth of the statements contained in this affidavit in awarding contracts for said project.

[Signature]
Bidder's Signature

12/20/24
Date Signed

STATE OF: Florida COUNTY OF: Volusia

The foregoing instrument was acknowledged before me by means of physical presence or online notarization this 30th day of Dec, 2024, by Nicholas M. Shephard as authorized representative of the bidder agency submitting this packet.

[Signature]
Notary Signature

Notary Stamp/Seal
FC DC#

Personally known _____ OR Produced Identification: 5163 633 84 1310
Type of ID presented: _____

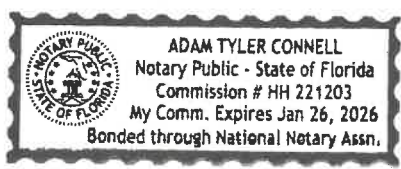

Request for Taxpayer Identification Number and Certification

Go to www.irs.gov/FormW9 for instructions and the latest information.

**Give form to the
 requester. Do not
 send to the IRS.**

Before you begin. For guidance related to the purpose of Form W-9, see *Purpose of Form*, below.

1 Name of entity/individual. An entry is required. (For a sole proprietor or disregarded entity, enter the owner's name on line 1, and enter the business/disregarded entity's name on line 2.)

Nicholas M Shephard

2 Business name/disregarded entity name, if different from above.

DDS Enterprises LLC

3a Check the appropriate box for federal tax classification of the entity/individual whose name is entered on line 1. Check only one of the following seven boxes.

- Individual/sole proprietor
 C corporation
 S corporation
 Partnership
 Trust/estate
 LLC. Enter the tax classification (C = C corporation, S = S corporation, P = Partnership) **S**

Note: Check the "LLC" box above and, in the entry space, enter the appropriate code (C, S, or P) for the tax classification of the LLC, unless it is a disregarded entity. A disregarded entity should instead check the appropriate box for the tax classification of its owner.

Other (see instructions)

4 Exemptions (codes apply only to certain entities, not individuals; see instructions on page 3):

Exempt payee code (if any) _____

Exemption from Foreign Account Tax Compliance Act (FATCA) reporting code (if any) _____

(Applies to accounts maintained outside the United States.)

3b If on line 3a you checked "Partnership" or "Trust/estate," or checked "LLC" and entered "P" as its tax classification, and you are providing this form to a partnership, trust, or estate in which you have an ownership interest, check this box if you have any foreign partners, owners, or beneficiaries. See instructions

5 Address (number, street, and apt. or suite no.). See instructions.

463 Shaw Lake Road

Requester's name and address (optional)

6 City, state, and ZIP code

Pierson, FI 32180

7 List account number(s) here (optional)

Print or type. See Specific Instructions on page 3.

Part I Taxpayer Identification Number (TIN)

Enter your TIN in the appropriate box. The TIN provided must match the name given on line 1 to avoid backup withholding. For individuals, this is generally your social security number (SSN). However, for a resident alien, sole proprietor, or disregarded entity, see the instructions for Part I, later. For other entities, it is your employer identification number (EIN). If you do not have a number, see *How to get a TIN*, later.

Note: If the account is in more than one name, see the instructions for line 1. See also *What Name and Number To Give the Requester* for guidelines on whose number to enter.

Social security number									

or

Employer identification number									
8	8	-	1	2	3	6	7	3	8

Part II Certification

Under penalties of perjury, I certify that:

- The number shown on this form is my correct taxpayer identification number (or I am waiting for a number to be issued to me); and
- I am not subject to backup withholding because (a) I am exempt from backup withholding, or (b) I have not been notified by the Internal Revenue Service (IRS) that I am subject to backup withholding as a result of a failure to report all interest or dividends, or (c) the IRS has notified me that I am no longer subject to backup withholding; and
- I am a U.S. citizen or other U.S. person (defined below); and
- The FATCA code(s) entered on this form (if any) indicating that I am exempt from FATCA reporting is correct.

Certification instructions. You must cross out item 2 above if you have been notified by the IRS that you are currently subject to backup withholding because you have failed to report all interest and dividends on your tax return. For real estate transactions, item 2 does not apply. For mortgage interest paid, acquisition or abandonment of secured property, cancellation of debt, contributions to an individual retirement arrangement (IRA), and, generally, payments other than interest and dividends, you are not required to sign the certification, but you must provide your correct TIN. See the instructions for Part II, later.

Sign Here

Signature of U.S. person

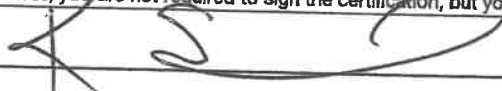

Date

8/30/24

General Instructions

Section references are to the Internal Revenue Code unless otherwise noted.

Future developments. For the latest information about developments related to Form W-9 and its instructions, such as legislation enacted after they were published, go to www.irs.gov/FormW9.

What's New

Line 3a has been modified to clarify how a disregarded entity completes this line. An LLC that is a disregarded entity should check the appropriate box for the tax classification of its owner. Otherwise, it should check the "LLC" box and enter its appropriate tax classification.

New line 3b has been added to this form. A flow-through entity is required to complete this line to indicate that it has direct or indirect foreign partners, owners, or beneficiaries when it provides the Form W-9 to another flow-through entity in which it has an ownership interest. This change is intended to provide a flow-through entity with information regarding the status of its indirect foreign partners, owners, or beneficiaries, so that it can satisfy any applicable reporting requirements. For example, a partnership that has any indirect foreign partners may be required to complete Schedules K-2 and K-3. See the Partnership Instructions for Schedules K-2 and K-3 (Form 1065).

Purpose of Form

An individual or entity (Form W-9 requester) who is required to file an information return with the IRS is giving you this form because they

Attachment F

Certification Regarding
Debarment, Suspension, Ineligibility
And Voluntary Exclusion

Subcontractor Covered Transactions

- (1) The prospective subcontractor, DDS Enterprises LLC, of the Recipient certifies, by submission of this document, that neither it nor its principals is presently debarred, suspended, proposed for debarment, declared ineligible, or voluntarily excluded from participation in this transaction by any Federal department or agency.
- (2) Where the Recipient's subcontractor is unable to certify to the above statement, the prospective subcontractor shall attach an explanation to this form.

SUBCONTRACTOR:

DDS Enterprises LLC

By: [Signature]
Signature

Nick Shepherd
Recipient's Name

Nick Shepherd VP
Name and Title

DEM Contract Number

463 Shew Lake Rd
Street Address

2024-05
Project Number

Aerion, FL 32180
City, State, Zip

12/30/24
Date

Town of Ponce Inlet RFP Form

Fire Station Generator

REQUEST FOR PROPOSAL (RFP)

Scope of Work:

The Town of Ponce Inlet is requesting a proposal for an emergency generator for the Fire Station located at 4680 South Peninsula Drive, Ponce Inlet Florida 32127. Proposals shall be submitted based on the purchase, installation, and integration of a 40Kw standby generator. The 40Kw generator can be either diesel or propane powered.

The Generator will be protected against a 500-year flood event or 7 feet above sea level by implementing specific activities or by locating the generator outside the Special Flood Hazard Area (SFHA) and will be protected against wind with a rated enclosure based on its location requirements. Activities will be completed in strict compliance with Federal, State and Local Rules and Regulations.

The Generator shall be designed/constructed/installed in accordance with the International Code Council's ICC/NSSA Standard for the Design and Construction of Storm Shelters (ICC 500-2014) or, where hurricane provisions are more stringent, NFPA 70E 2020, the 2023 Florida Building Code, 8th Edition (Risk Category IV Buildings).

The contractor will be responsible for the permit and engineering to install and integrate the generator to Public Works. After completion of the integration of the generator the contractor will provide a one-hour training session about the generator to Public Works staff.

Deadline:

Please return this Request for Proposal Form addressed to Town Clerk, Town of Ponce Inlet, 4300 S. Atlantic Avenue, Ponce Inlet, FL 32127 in a SEALED ENVELOPE plainly marked on the outside "RFP 2024-05 Fire Station Generator" with a Lump Sum Price by with a Lump Sum Price by **2:00 pm, Monday December 30, 2024.**

Scope of Work:**Lump Sum/Unit Pricing:**

ITEM NO.	DESCRIPTION	EST QUANTITY	UNIT	AMOUNT PROPOSAL
1	40Kw Generator Project	1	LS	\$106,155.03
LUMP SUM TOTAL				\$106,155.03

NOTE: This is for LUMP SUM COST of the entire project, unit prices are to establish pricing if additional work is required above or beyond the Lump Sum Base Price.

Vendor Name:	Zabatt Engine Services, Inc.	Date:	12/26/2024
Company:	Zabatt Engine Services, Inc.		
Phone #:	904-384-4505	eMail:	bids@zabatt.com / sales@zabatt.com
Signature:		Print Name:	Sandra M. Sabatier

Attachment F

Certification Regarding Debarment, Suspension, Ineligibility And Voluntary Exclusion

Subcontractor Covered Transactions

- (1) The prospective subcontractor, Zabatt Engine Services, Inc., of the Recipient certifies, by submission of this document, that neither it nor its principals is presently debarred, suspended, proposed for debarment, declared ineligible, or voluntarily excluded from participation in this transaction by any Federal department or agency.

- (2) Where the Recipient's subcontractor is unable to certify to the above statement, the prospective subcontractor shall attach an explanation to this form.

SUBCONTRACTOR:

Zabatt Engine Services, Inc.

By: 	<u>Town of Ponce Inlet</u>
Signature	Recipient's Name

<u>Sandra M. Sabatier - Secretary</u>	<u></u>
Name and Title	DEM Contract Number

<u>4612 Highway Avenue</u>	<u>2024-05-0-2024/DS</u>
Street Address	Project Number

Jacksonville, FL 32254

City, State, Zip

12/3/2024

Date



Request for Taxpayer Identification Number and Certification

Go to www.irs.gov/FormW9 for instructions and the latest information.

Give form to the
 requester. Do not
 send to the IRS.

Before you begin. For guidance related to the purpose of Form W-9, see *Purpose of Form*, below.

Print or type. See Specific Instructions on page 3.	1 Name of entity/individual. An entry is required. (For a sole proprietor or disregarded entity, enter the owner's name on line 1, and enter the business/disregarded entity's name on line 2.) Zabatt Engine Services, Inc.	
	2 Business name/disregarded entity name, if different from above. dba / Zabatt, Inc. and dba / Zabatt Power Systems, Inc.	
	3a Check the appropriate box for federal tax classification of the entity/individual whose name is entered on line 1. Check only one of the following seven boxes. <input type="checkbox"/> Individual/sole proprietor <input type="checkbox"/> C corporation <input checked="" type="checkbox"/> S corporation <input type="checkbox"/> Partnership <input type="checkbox"/> Trust/estate <input type="checkbox"/> LLC. Enter the tax classification (C = C corporation, S = S corporation, P = Partnership) _____ Note: Check the "LLC" box above and, in the entry space, enter the appropriate code (C, S, or P) for the tax classification of the LLC, unless it is a disregarded entity. A disregarded entity should instead check the appropriate box for the tax classification of its owner. <input type="checkbox"/> Other (see instructions) _____	
	4 Exemptions (codes apply only to certain entities, not individuals; see instructions on page 3): Exempt payee code (if any) <u>5</u> Exemption from Foreign Account Tax Compliance Act (FATCA) reporting code (if any) _____ <i>(Applies to accounts maintained outside the United States.)</i>	
	3b If on line 3a you checked "Partnership" or "Trust/estate," or checked "LLC" and entered "P" as its tax classification, and you are providing this form to a partnership, trust, or estate in which you have an ownership interest, check this box if you have any foreign partners, owners, or beneficiaries. See instructions _____ <input type="checkbox"/>	
	5 Address (number, street, and apt. or suite no.). See instructions. 4612 Highway Avenue	Requester's name and address (optional)
	6 City, state, and ZIP code Jacksonville, FL 32254	
7 List account number(s) here (optional)		

Part I Taxpayer Identification Number (TIN)

Enter your TIN in the appropriate box. The TIN provided must match the name given on line 1 to avoid backup withholding. For individuals, this is generally your social security number (SSN). However, for a resident alien, sole proprietor, or disregarded entity, see the instructions for Part I, later. For other entities, it is your employer identification number (EIN). If you do not have a number, see *How to get a TIN*, later.

Social security number									
[] [] [] []	- [] [] - [] [] [] []								
or									
Employer identification number									
5	9	-	1	8	8	9	2	7	1

Note: If the account is in more than one name, see the instructions for line 1. See also *What Name and Number To Give the Requester* for guidelines on whose number to enter.

Part II Certification

Under penalties of perjury, I certify that:

1. The number shown on this form is my correct taxpayer identification number (or I am waiting for a number to be issued to me); and
2. I am not subject to backup withholding because (a) I am exempt from backup withholding, or (b) I have not been notified by the Internal Revenue Service (IRS) that I am subject to backup withholding as a result of a failure to report all interest or dividends, or (c) the IRS has notified me that I am no longer subject to backup withholding; and
3. I am a U.S. citizen or other U.S. person (defined below); and
4. The FATCA code(s) entered on this form (if any) indicating that I am exempt from FATCA reporting is correct.

Certification instructions. You must cross out item 2 above if you have been notified by the IRS that you are currently subject to backup withholding because you have failed to report all interest and dividends on your tax return. For real estate transactions, item 2 does not apply. For mortgage interest paid, acquisition or abandonment of secured property, cancellation of debt, contributions to an individual retirement arrangement (IRA), and, generally, payments other than interest and dividends, you are not required to sign the certification, but you must provide your correct TIN. See the instructions for Part II, later.

Sign Here	Signature of U.S. person	Date 4/10/2024
------------------	--------------------------	-----------------------

General Instructions

Section references are to the Internal Revenue Code unless otherwise noted.

Future developments. For the latest information about developments related to Form W-9 and its instructions, such as legislation enacted after they were published, go to www.irs.gov/FormW9.

What's New

Line 3a has been modified to clarify how a disregarded entity completes this line. An LLC that is a disregarded entity should check the appropriate box for the tax classification of its owner. Otherwise, it should check the "LLC" box and enter its appropriate tax classification.

New line 3b has been added to this form. A flow-through entity is required to complete this line to indicate that it has direct or indirect foreign partners, owners, or beneficiaries when it provides the Form W-9 to another flow-through entity in which it has an ownership interest. This change is intended to provide a flow-through entity with information regarding the status of its indirect foreign partners, owners, or beneficiaries, so that it can satisfy any applicable reporting requirements. For example, a partnership that has any indirect foreign partners may be required to complete Schedules K-2 and K-3. See the Partnership Instructions for Schedules K-2 and K-3 (Form 1065).

Purpose of Form

An individual or entity (Form W-9 requester) who is required to file an information return with the IRS is giving you this form because they



Meeting Date: 3/20/2025

Agenda Item: 13-C

Report to Town Council

Topic: Acceptance of bid from Alternative Current Electric for the replacement Public Works generator.

Summary: See attached staff report and supporting documents.

Suggested motion: Staff recommends the award of Bid 2025-02 to Alternative Current Electric for \$92,500 and authorize the Town Manager to execute all necessary agreements to proceed with the project.

Requested by: Mr. Wargo, Public Works Director

Approved by: Mr. Disher, Town Manager



MEMORANDUM

TOWN OF PONCE INLET, PUBLIC WORKS DEPARTMENT

The Town of Ponce Inlet staff shall be professional, caring and fair in delivering community excellence while ensuring Ponce Inlet residents obtain the greatest value for their tax dollar.

To: Michael E. Disher, AICP, Town Manager

From: Steven Wargo, Public Works Director

Date: March 6, 2025

Subject: Replacement Emergency Generator – Public Works

MEETING DATE: March 20, 2025

Background:

The existing emergency generator at the Public Works facility is no longer repairable and must be replaced to ensure the continuity of essential emergency operations. Acknowledging the importance of reliable power during critical situations, last year the Town Council budgeted funds for the procurement and installation of a replacement emergency generator, as well as the transfer of incoming power from the former Building B to the current office building at Public Works.

Bid Process:

The Town advertised Bid #2025-02 for the replacement and installation of an emergency generator in accordance with procurement policies. Four bids were received and evaluated based on cost, compliance with the bid specifications, and contractor qualifications:

- Alternative Current Electric: \$92,500
- Accurate Power and Technology: \$98,500
- Zabbatt Engine Services: \$100,038.61
- DDS Enterprises: \$108,950

Alternative Current Electric provided the lowest bid and demonstrated the capability to meet all project requirements within the available budget.

Fiscal Impact:

The total project cost of \$92,500 is fully covered under the Land Acquisition Fund for Capital Improvements.

Recommendation:

Staff recommends that the Town Council approve the award of Bid #2025-02 to Alternative Current Electric for \$92,500, and authorize the Town Manager to execute all necessary agreements to proceed with the project.

Town of Ponce Inlet RFP Form
Public Works Emergency Generator

REQUEST FOR PROPOSAL #2025-02 (RFP #2025-02)

Scope of Work:

The Town of Ponce Inlet is requesting a proposal for an emergency generator for the Public Works compound located at 4875 South Peninsula Drive, Ponce Inlet Florida 32127. Proposals shall be submitted based on the purchase, installation, and integration of a 40Kw standby generator. The 40Kw generator can be either diesel or propane powered.

The Generator will be relocated on site to accommodate the addition of a new building. The main electrical service to the compound and transfer switch will need to be relocated as part of this project to also accommodate the addition of a new building. Activities will be completed in strict compliance with Federal, State and Local Codes and Regulations.

The Generator shall be designed/constructed/installed in accordance with the 2023 Florida Building Code and 2020 NEC.

The contractor will be responsible for the permit and engineering to move the main electrical feed and transfer switch to install and integrate the generator into the Public Works main building. After completion of the integration of the generator the contractor will provide a one-hour training session about the generator for Public Works staff.

Deadline:

Please return this Request for Proposal Form addressed to Town Clerk, Town of Ponce Inlet, 4300 S. Atlantic Avenue, Ponce Inlet, FL 32127 in a SEALED ENVELOPE plainly marked on the outside "RFP 2025-02 Public Works Emergency Generator" with a Lump Sum Price by 2:00 pm, Friday, February 28, 2025.

Lump Sum/Unit Pricing:

Table with 5 columns: ITEM NO., DESCRIPTION, EST QUANTITY, UNIT, AMOUNT PROPOSAL. Rows include 40Kw Generator, Move main power feed, Alternate for New Transfer Switch, and LUMP SUM TOTAL \$92,500.00.

NOTE: This is for LUMP SUM COST of the entire project, unit prices are to establish pricing if additional work is required above or beyond the Lump Sum Base Price.

Vendor information table with fields: Vendor Name (Bryan Anderosn), Date (02/28/2025), Company (Alternative Current Electric), Phone # (386) 281-0139, eMail (Bryan@alternativecurrentelectric.com), Signature (Bryan Anderson), Print Name (Bryan Anderson).

Alternative Current Electric

320 Division Ave Ste D
Ormond Beach, FL 32174
(386) 218-0139 | (240) 520-2465
EC13013220 | ER13016293



2/27/25 Electrical Proposal for the Public Works Emergency Generator – Ponce Inlet, FL prepared for:

Town of Ponce Inlet

Per Site visit with Steve Wargo on 2/26/25, Proposed Site Plan Drawings and Request for Proposal form #2025-02 (RFP #2025-02) provided by the Town of Ponce Inlet:

Demo existing generator and conductors

Includes haul-off of old generator; excludes demo of old concrete generator pad

Provide and install a new Cummins 200A, 120/240V single-phase 50kW diesel generator with base **24HR** runtime diesel fuel tank

Includes external emergency stop switch, battery racks, cables, charger, fluids, and concrete pad for generator

Note: Cummins does not manufacture a 40kW generator

Quote also includes 1-year service contract by "Advanced Generators" (quarterly inspections and first oil change), and a one-hour training session for Public Works staff to orient them on new emergency power system

\$25,000.00 deposit for generator required before ordering generator

Provide and install new 200A utility meter and service entrance-rated automatic transfer switch on the north side of "Existing Building"

Also includes new outdoor single-phase 200A 120/240V load-center with feed through lugs, figured as installed next to the new meter and ATS

Note: quote DOES NOT figure re-use/relocation of existing utility meter and disconnect from condemned building, but rather includes new single-phase service equipment

An exterior panel is necessary to provide required exterior service receptacle, to feed generator circuitry (heater and charger), to re-feed existing "water tower" shed, and to re-feed existing building's interior load center panel; and quote includes completing all of this scope

New feed to the "old water tower" shed is figured as a dedicated 120V 20A circuit

New feed to existing building's interior load-center figured as single-phase 200A AL conductors in 2" conduit

New electric service figured as single-phase 200A 120/240V in 2" PVC conduit

Conductors for generator figured as copper, which is required by Cummins

Figures all existing equipment to be reused is in working/serviceable order (particularly load-center of existing building)

Includes new conduit and conductors from existing FPL handhole to new service meter, and coordinating with FPL on disconnect of existing service and reconnect of new service
Existing service will be disconnected; demo of it figured as part of eventual demo of condemned building (though service will be inactive and safe to demo at that point)

Includes permitting work
Permitting fees in excess of \$300.00 to be passed on to owner
Electrical engineering, if required, to be provided by Alternative Current Electric as permitted by EC license given size of proposed new electric service

Excludes:

Utility company fees (none foreseen)
Payment and performance bond
Lighting protection
Demo of any buildings and/or structures
Initial fill-up of diesel fuel tank (required for start-up)
Any new power or wiring for the lift station

We hereby propose to furnish labor and materials, complete in accordance with the above specifications for the sum of: \$92,500.00

**For 120HR run time fuel tank, add \$5,250.00 to base pricing
Includes all labor and material
FDEP registration/fees, if applicable, by others**

All work to be completed in a professional and workmanlike manner. Any work done outside of scope included herein to be priced separately and included as an extra charge at the discretion of the undersigned. Material pricing is good for 30 days only from the date of proposal. Project billing figured as monthly, progress billing with NET 30 terms.

Authorized Signature: Bryan Anderson 

Acceptance of Proposal – Please sign and return one copy

The above prices, specifications and conditions are hereby accepted. You are authorized to do the work as specified.

Authorized Signature:

Date:



Ron DeSantis, Governor

Melanie S. Griffin, Secretary



STATE OF FLORIDA
DEPARTMENT OF BUSINESS AND PROFESSIONAL REGULATION

ELECTRICAL CONTRACTORS' LICENSING BOARD

THE ELECTRICAL CONTRACTOR HEREIN IS CERTIFIED UNDER THE
PROVISIONS OF CHAPTER 489, FLORIDA STATUTES

ANDERSON, BRYAN J.

ALTERNATIVE CURRENT ELECTRIC, LLC
320 DIVISION AVE STE D
ORMOND BEACH FL 32174

LICENSE NUMBER: EC13013220

EXPIRATION DATE: AUGUST 31, 2026

Always verify licenses online at MyFloridaLicense.com



ISSUED: 05/22/2024

Do not alter this document in any form.

This is your license. It is unlawful for anyone other than the licensee to use this document.

Request for Taxpayer Identification Number and Certification

Give Form to the requester. Do not send to the IRS.

▶ Go to www.irs.gov/FormW9 for instructions and the latest information.

1 Name (as shown on your income tax return). Name is required on this line; do not leave this line blank.

Alternative Current Electric, LLC

2 Business name/disregarded entity name, if different from above

3 Check appropriate box for federal tax classification of the person whose name is entered on line 1. Check only **one** of the following seven boxes.

Individual/sole proprietor or single-member LLC

C Corporation

S Corporation

Partnership

Trust/estate

Limited liability company. Enter the tax classification (C=C corporation, S=S corporation, P=Partnership) ▶ **S**

Note: Check the appropriate box in the line above for the tax classification of the single-member owner. Do not check LLC if the LLC is classified as a single-member LLC that is disregarded from the owner unless the owner of the LLC is another LLC that is **not** disregarded from the owner for U.S. federal tax purposes. Otherwise, a single-member LLC that is disregarded from the owner should check the appropriate box for the tax classification of its owner.

Other (see instructions) ▶

4 Exemptions (codes apply only to certain entities, not individuals; see instructions on page 3):

Exempt payee code (if any) _____

Exemption from FATCA reporting code (if any) _____

(Applies to accounts maintained outside the U.S.)

5 Address (number, street, and apt. or suite no.) See instructions.

Requester's name and address (optional)

320 Division Ave Ste D

6 City, state, and ZIP code

Ormond Beach, FL 32174

7 List account number(s) here (optional)

Print or type. See Specific Instructions on page 3.

Part I Taxpayer Identification Number (TIN)

Enter your TIN in the appropriate box. The TIN provided must match the name given on line 1 to avoid backup withholding. For individuals, this is generally your social security number (SSN). However, for a resident alien, sole proprietor, or disregarded entity, see the instructions for Part I, later. For other entities, it is your employer identification number (EIN). If you do not have a number, see *How to get a TIN*, later.

Note: If the account is in more than one name, see the instructions for line 1. Also see *What Name and Number To Give the Requester* for guidelines on whose number to enter.

Social security number								
				-				

or

Employer identification number									
8	6	-	3	7	7	5	4	0	1

Part II Certification

Under penalties of perjury, I certify that:

- The number shown on this form is my correct taxpayer identification number (or I am waiting for a number to be issued to me); and
- I am not subject to backup withholding because: (a) I am exempt from backup withholding, or (b) I have not been notified by the Internal Revenue Service (IRS) that I am subject to backup withholding as a result of a failure to report all interest or dividends, or (c) the IRS has notified me that I am no longer subject to backup withholding; and
- I am a U.S. citizen or other U.S. person (defined below); and
- The FATCA code(s) entered on this form (if any) indicating that I am exempt from FATCA reporting is correct.

Certification instructions. You must cross out item 2 above if you have been notified by the IRS that you are currently subject to backup withholding because you have failed to report all interest and dividends on your tax return. For real estate transactions, item 2 does not apply. For mortgage interest paid, acquisition or abandonment of secured property, cancellation of debt, contributions to an individual retirement arrangement (IRA), and generally, payments other than interest and dividends, you are not required to sign the certification, but you must provide your correct TIN. See the instructions for Part II, later.

Sign Here

Signature of U.S. person ▶



Date ▶ 2/28/25

General Instructions

Section references are to the Internal Revenue Code unless otherwise noted.

Future developments. For the latest information about developments related to Form W-9 and its instructions, such as legislation enacted after they were published, go to www.irs.gov/FormW9.

Purpose of Form

An individual or entity (Form W-9 requester) who is required to file an information return with the IRS must obtain your correct taxpayer identification number (TIN) which may be your social security number (SSN), individual taxpayer identification number (ITIN), adoption taxpayer identification number (ATIN), or employer identification number (EIN), to report on an information return the amount paid to you, or other amount reportable on an information return. Examples of information returns include, but are not limited to, the following.

- Form 1099-INT (interest earned or paid)

- Form 1099-DIV (dividends, including those from stocks or mutual funds)
- Form 1099-MISC (various types of income, prizes, awards, or gross proceeds)
- Form 1099-B (stock or mutual fund sales and certain other transactions by brokers)
- Form 1099-S (proceeds from real estate transactions)
- Form 1099-K (merchant card and third party network transactions)
- Form 1098 (home mortgage interest), 1098-E (student loan interest), 1098-T (tuition)
- Form 1099-C (canceled debt)
- Form 1099-A (acquisition or abandonment of secured property)

Use Form W-9 only if you are a U.S. person (including a resident alien), to provide your correct TIN.

If you do not return Form W-9 to the requester with a TIN, you might be subject to backup withholding. See What is backup withholding, later.

Attachment F

**Certification Regarding
Debarment, Suspension, Ineligibility
And Voluntary Exclusion**

Subcontractor Covered Transactions

- (1) The prospective subcontractor, Alternative Current Electric, of the Recipient certifies, by submission of this document, that neither it nor its principals is presently debarred, suspended, proposed for debarment, declared ineligible, or voluntarily excluded from participation in this transaction by any Federal department or agency.
- (2) Where the Recipient's subcontractor is unable to certify to the above statement, the prospective subcontractor shall attach an explanation to this form.

SUBCONTRACTOR:

Alternative Current Electric

By: Bryan Anderson
Signature

Bryan Anderson
Recipient's Name

Bryan Anderson, Managing Member

Name and Title

DEM Contract Number

320 Division Ave Ste D

Street Address

Project Number

Ormond Beach, Fl 32174

City, State, Zip

02/28/2025

Date

NON-COLLUSION AFFIDAVIT

I, Bryan Anderson, depose and say that:

- 1. I am managing member of the firm Alternative Current Electric, the firm submitting the response described in this Request for Proposals; and that I executed the said response with full authority to do so;
- 2. The prices in this bid have been arrived at independently without collusion, consultation, communication, or agreement for the purpose of restricting competition, as to any matter relating to such prices with any other bidder or with any competitor;
- 3. Unless otherwise required by law, the prices which have been quoted in this bid have not been knowingly disclosed by the bidder and will not knowingly be disclosed by the bidder prior to bid opening, directly or indirectly, to any other bidder or to any competitor;
- 4. No attempt has been made or will be made by the bidder to induce any other person, partnership, or corporation to submit, or not to submit, a bid for the purpose of restricting competition; and
- 5. The statements contained in this affidavit are true and correct, and made with full knowledge that the Town of Ponce Inlet relies upon the truth of the statements contained in this affidavit in awarding contracts for said project.

Bryan Anderson
Bidder's Signature

2/28/25
Date Signed

STATE OF: Florida COUNTY OF: Volusia

The foregoing instrument was acknowledged before me by means of physical presence or online notarization

this 28 day of Feb, 2025, by Bryan Anderson

ST
as authorized representative of the bidder agency submitting this packet.

Spencer Taylor
Notary Signature

Notary Stamp/Seal

SPENCER TAYLOR
 Notary Public
 State of Florida
 Comm# HH291445
 Expires 7/24/2026

Personally known OR _____ Produced Identification: _____
Type of ID presented: _____



15519 U.S. Hwy 441
Suite A101
Eustis, FL 32726
Office: 352-735-8285
Fax: 352-609-5165

Accurate Power and Technology, Inc is a State Certified Electrical Contractor since 2005, (S-CORP) EIN (20-2663060), LIC (EC13007737) DUNS (36-247-2800) E-Verify (1651230) that specializes in Back Up Power and Commercial Electric. It is our intent to Contract with Ponce Inlet for RFP 2025-02.

We understand the scope defined as Removal and Installation of a new Generator and to relocate the existing service. No Exceptions are taken for this submittal. All work to be completed with the upmost quality and in a timely manner consciously and having the counties best interest in mind.

Accurate Power currently holds “Brick and Mortar” in Central Florida (Eustis) and the West Coast of Florida (Sarasota).

Accurate Power Manages approx. 5500 Engines around the state and has been doing so for 18 years.

1. **Eustis – 15519 West US Highway 441 Suite A101 Eustis, FL 32726 (352.735.8285 Office) (Proposing Office) (352.609.5165 FAX)**
2. **Sarasota – 6341 Porter Road Unit 8 Sarasota, FL 34240 (941.867.6580 Office)**

Below is a list of Full Time Employees and procedures:

1. Sonny J Dukes, President, Lead Industrial Technical Advisor 6σ, 407.280.7904
2. Shannon M Dukes, VP, PMP, MBA 352.735.8285
3. Jack Phillips, EC Qualifier 727.858.0687
4. David Kornstadt, Commercial AE 352.805.5024
5. Haley Bogart AR/AP 352.735.8285
6. Brian Eakin, Operations Manager, Lead Certified Industrial Technician 352.735.8285
7. Chris Ethridge, Lead Electrical, Lic Journeyman, Staff Engineer and Estimator 352.735.8285
8. Toni Hayden, Service Manager, Parts, Warranty and Quoting 352.735.8285
9. Allen Green – Lead Industrial Diesel 352.735.8285
10. On-Call 352.735.8285 (prompts)

We are currently staffed to complete 12 million in Revenue annually. **Our service department supports some large clients to date such as FDOT, Seminole County, Mt Dora, Pinellas County Schools, Orlando Utilities, City of Altamonte Spring, Florida Keys, FDVA, FDEMS, and FDEMS. We also support several “Life Safety” Clients such as nursing homes and assisted living facilities. All 24 of our Vehicles are 2018/2019/2022 and are either owned by us or Enterprise Fleet. All (Uniformed)Technicians hold Jessica Lunsford certification.**

All contents of this proposal are true and accurate, all requirements for this Bid Proposal can be met, including, but not limited to, insurance, bonding, and licensing, and Certifications.

MISSION STATEMENT AND CORE VALUES

Accurate Power and technology provide the best possible cutting-edge backup power product for any budget. We focus on the best value and service across every client we serve.

1. We believe our employees come first and we respect our suppliers.
2. We stay involved in our community and are dedicated to our chosen organizations to help less fortunate.
3. We have passion for execution.
4. We will be focused on our experience rather than price.
5. We will strive to achieve 100% customer satisfaction.

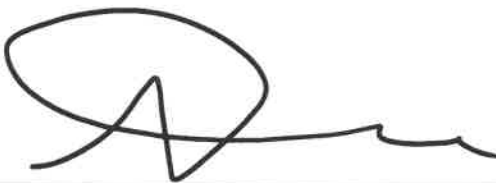

_____, President 1/13/2025

Sonny J Duker
Controller, Accurate Power and Technology, Inc
EC13007737
6σ, ITIL, NET+, SEC+
OFFICE: 352.735.8285
15519 West US Highway 441
Suite 101A
Eustis, FL 32726

Town of Ponce Inlet RFP Form

Public Works Emergency Generator

REQUEST FOR PROPOSAL #2025-02 (RFP #2025-02)

Scope of Work:

The Town of Ponce Inlet is requesting a proposal for an emergency generator for the Public Works compound located at 4875 South Peninsula Drive, Ponce Inlet Florida 32127. Proposals shall be submitted based on the purchase, installation, and integration of a 40Kw standby generator. The 40Kw generator can be either diesel or propane powered.

The Generator will be relocated on site to accommodate the addition of a new building. The main electrical service to the compound and transfer switch will need to be relocated as part of this project to also accommodate the addition of a new building. Activities will be completed in strict compliance with Federal, State and Local Codes and Regulations.

The Generator shall be designed/constructed/installed in accordance with the 2023 Florida Building Code and 2020 NEC.

The contractor will be responsible for the permit and engineering to move the main electrical feed and transfer switch to install and integrate the generator into the Public Works main building. After completion of the integration of the generator the contractor will provide a one-hour training session about the generator for Public Works staff.

Deadline:

Please return this Request for Proposal Form addressed to Town Clerk, Town of Ponce Inlet, 4300 S. Atlantic Avenue, Ponce Inlet, FL 32127 in a SEALED ENVELOPE plainly marked on the outside “**RFP 2025-02 Public Works Emergency Generator**” with a Lump Sum Price by **2:00 pm, Friday, February 28, 2025.**

Lump Sum/Unit Pricing:

ITEM NO.	DESCRIPTION	EST QUANTITY	UNIT	AMOUNT PROPOSAL
1	40Kw Generator	1	LS	39,513.00
2	Move main power feed <i>+ Install</i>	1	LS	52,427.00
3	Alternate for New Transfer Switch	1	LS	65,000.00
<i>Has to have a switch installed.</i>				LUMP SUM TOTAL \$98,500.00

NOTE: This is for LUMP SUM COST of the entire project, unit prices are to establish pricing if additional work is required above or beyond the Lump Sum Base Price.

Vendor Name:	Accurate Power and Technology	Date:	2-20-25
Company:	Sonny J. Dukes, President		
Phone #:	352.735.8288	eMail:	sonny@accuratepowerandtechnology.com
Signature:		Print Name:	Sonny J. Dukes.



Addendum #1

Town of Ponce Inlet

Public Works Generator - RFP No. 2025-02

Q&A

1. *What is the estimated construction budget for this project?*

Answer – \$100,000

Please include proof insurance with proposal.

Debbie Stewart, Assistant Deputy Clerk
Addendum #1 – dated 2/06/2025

Proposed Site Plan



CONCEPTUAL PLAN NOTES:

1. ALL EXISTING UTILITIES ARE SHOWN FOR INFORMATION ONLY.
2. THIS CONCEPTUAL PLAN IS FOR INFORMATION ONLY AND DOES NOT REPRESENT A FINAL DESIGN OR CONTRACT DOCUMENT.
3. THE CLIENT IS RESPONSIBLE FOR OBTAINING ALL NECESSARY PERMITS AND APPROVALS FROM THE LOCAL, STATE, AND FEDERAL AUTHORITIES.
4. THE CONCEPTUAL PLAN IS BASED ON THE INFORMATION PROVIDED BY THE CLIENT AND IS SUBJECT TO CHANGE WITHOUT NOTICE.
5. EXISTING INFORMATION PROVIDED BY THE CLIENT IS ASSUMED TO BE ACCURATE AND COMPLETE.
6. THE INFORMATION SHOWN ON THIS CONCEPTUAL PLAN IS FOR INFORMATION ONLY AND IS NOT TO BE USED FOR ANY OTHER PURPOSE.
7. ALL DIMENSIONS AND LOCATIONS ARE APPROXIMATE AND SUBJECT TO CHANGE.



PONCE INLET PUBLIC WORKS CP2 VOLUSIA COUNTY, FLORIDA

11/15/2023 10:00 AM - 11/15/2023 10:00 AM

Request for Taxpayer Identification Number and Certification

Give Form to the requester. Do not send to the IRS.

▶ Go to www.irs.gov/FormW9 for instructions and the latest information.

Print or type. See Specific Instructions on page 3.	1 Name (as shown on your income tax return). Name is required on this line; do not leave this line blank. Accurate Power and Technology, Inc		
	2 Business name/disregarded entity name, if different from above A Generator Guy		
	3 Check appropriate box for federal tax classification of the person whose name is entered on line 1. Check only one of the following seven boxes.		
	<input type="checkbox"/> Individual/sole proprietor or single-member LLC <input type="checkbox"/> C Corporation <input checked="" type="checkbox"/> S Corporation <input type="checkbox"/> Partnership <input type="checkbox"/> Trust/estate		
	<input type="checkbox"/> Limited liability company. Enter the tax classification (C=C corporation, S=S corporation, P=Partnership) ▶ _____ Note: Check the appropriate box in the line above for the tax classification of the single-member owner. Do not check LLC if the LLC is classified as a single-member LLC that is disregarded from the owner unless the owner of the LLC is another LLC that is not disregarded from the owner for U.S. federal tax purposes. Otherwise, a single-member LLC that is disregarded from the owner should check the appropriate box for the tax classification of its owner.		
	<input type="checkbox"/> Other (see instructions) ▶ _____		
	5 Address (number, street, and apt. or suite no.) See Instructions. 15519 West Us Highway 441 Suite A101		Requester's name and address (optional)
6 City, state, and ZIP code Eustis, FL 32726			
7 List account number(s) here (optional)			

Part I Taxpayer Identification Number (TIN)

Enter your TIN in the appropriate box. The TIN provided must match the name given on line 1 to avoid backup withholding. For individuals, this is generally your social security number (SSN). However, for a resident alien, sole proprietor, or disregarded entity, see the instructions for Part I, later. For other entities, it is your employer identification number (EIN). If you do not have a number, see *How to get a TIN*, later.

Note: If the account is in more than one name, see the instructions for line 1. Also see *What Name and Number To Give the Requester* for guidelines on whose number to enter.

Social security number									
or									
Employer identification number									
2	0	-	2	6	6	3	0	6	0

Part II Certification

Under penalties of perjury, I certify that:

- The number shown on this form is my correct taxpayer identification number (or I am waiting for a number to be issued to me); and
- I am not subject to backup withholding because: (a) I am exempt from backup withholding, or (b) I have not been notified by the Internal Revenue Service (IRS) that I am subject to backup withholding as a result of a failure to report all interest or dividends, or (c) the IRS has notified me that I am no longer subject to backup withholding; and
- I am a U.S. citizen or other U.S. person (defined below); and
- The FATCA code(s) entered on this form (if any) indicating that I am exempt from FATCA reporting is correct.

Certification instructions. You must cross out item 2 above if you have been notified by the IRS that you are currently subject to backup withholding because you have failed to report all interest and dividends on your tax return. For real estate transactions, item 2 does not apply. For mortgage interest paid, acquisition or abandonment of secured property, cancellation of debt, contributions to an individual retirement arrangement (IRA), and generally, payments other than interest and dividends, you are not required to sign the certification, but you must provide your correct TIN. See the instructions for Part II, later.

Sign Here	Signature of U.S. person ▶ <i>Sonny Dukas</i>	Date ▶ 1/1/2025
------------------	---	-----------------

General Instructions

Section references are to the Internal Revenue Code unless otherwise noted.

Future developments. For the latest information about developments related to Form W-9 and its instructions, such as legislation enacted after they were published, go to www.irs.gov/FormW9.

Purpose of Form

An individual or entity (Form W-9 requester) who is required to file an information return with the IRS must obtain your correct taxpayer identification number (TIN) which may be your social security number (SSN), individual taxpayer identification number (ITIN), adoption taxpayer identification number (ATIN), or employer identification number (EIN), to report on an information return the amount paid to you, or other amount reportable on an information return. Examples of information returns include, but are not limited to, the following.

- Form 1099-DIV (dividends, including those from stocks or mutual funds)
- Form 1099-MISC (various types of income, prizes, awards, or gross proceeds)
- Form 1099-B (stock or mutual fund sales and certain other transactions by brokers)
- Form 1099-S (proceeds from real estate transactions)
- Form 1099-K (merchant card and third party network transactions)
- Form 1098 (home mortgage interest), 1098-E (student loan interest), 1098-T (tuition)
- Form 1099-C (canceled debt)
- Form 1099-A (acquisition or abandonment of secured property)

Use Form W-9 only if you are a U.S. person (including a resident alien), to provide your correct TIN.

If you do not return Form W-9 to the requester with a TIN, you might be subject to backup withholding. See What is backup withholding, later.

Attachment F

**Certification Regarding
Debarment, Suspension, Ineligibility
And Voluntary Exclusion**

Subcontractor Covered Transactions

- (1) The prospective subcontractor, _____, of the Recipient certifies, by submission of this document, that neither it nor its principals is presently debarred, suspended, proposed for debarment, declared ineligible, or voluntarily excluded from participation in this transaction by any Federal department or agency.
- (2) Where the Recipient's subcontractor is unable to certify to the above statement, the prospective subcontractor shall attach an explanation to this form.

SUBCONTRACTOR:

No subs used.

By: _____
Signature

Recipient's Name

Name and Title

DEM Contract Number

Street Address

Project Number

City, State, Zip

Date

NON-COLLUSION AFFIDAVIT

I, Sonny J. Dukes, depose and say that:

1. I am President of the firm Accurate Power & Tech. the firm submitting the response described in this Request for Proposals; and that I executed the said response with full authority to do so;
2. The prices in this bid have been arrived at independently without collusion, consultation, communication, or agreement for the purpose of restricting competition, as to any matter relating to such prices with any other bidder or with any competitor;
3. Unless otherwise required by law, the prices which have been quoted in this bid have not been knowingly disclosed by the bidder and will not knowingly be disclosed by the bidder prior to bid opening, directly or indirectly, to any other bidder or to any competitor;
4. No attempt has been made or will be made by the bidder to induce any other person, partnership, or corporation to submit, or not to submit, a bid for the purpose of restricting competition; and
5. The statements contained in this affidavit are true and correct, and made with full knowledge that the Town of Ponce Inlet relies upon the truth of the statements contained in this affidavit in awarding contracts for said project.

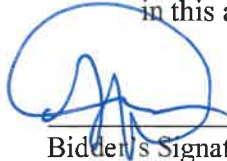

Bidder's Signature

2-20-25
Date Signed

STATE OF: Florida COUNTY OF: Lake

The foregoing instrument was acknowledged before me by means of physical presence or online notarization

this 18th day of Feb., 2024, by Sonny Dukes

_____ as authorized representative of the bidder agency submitting this packet.

Kimberly Slotnick
Notary Signature

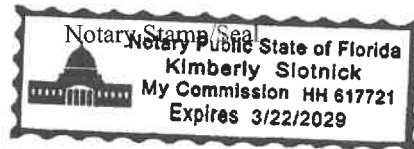

Personally known OR _____ Produced Identification: _____

Type of ID presented: _____



15519 U.S. Hwy 441
Eustis, FL 32726
Office: 352-735-8285
Fax: 352-609-5165

Qualifications and Experience

Accurate Power and Technology, Inc is a State Certified Electrical Contractor that specializes in Back Up Power and Commercial Electrical Service. Our Mission Statement and Core Values will explain our required commitment to customer satisfaction and businesslike concerns for our clients.

MISSION STATEMENT AND CORE VALUES

Accurate Power and technology provide the best possible cutting-edge backup power product for any budget. We focus on the best value and service across every client we serve.

1. We believe our employees come first and we respect our suppliers.
2. We stay involved in our community and are dedicated to our chosen organizations to help less fortunate.
3. We have passion for execution.
4. We will be experience focused rather than price.
5. We will strive to achieve 100% customer satisfaction.

We have successfully completed administratively and Operationally Major Service and Installation work for several large clients including. We have never missed a budget or schedule. Below we have listed some of the contracts we have held over the last 10 years

1. Department of Transportation (**MOT Certified**)
2. Department of Agriculture
3. Florida Department of Health
4. Orange County
5. Lake County
6. Pinellas County Schools Board
7. City of Altamonte Springs
8. Orlando Utilities
9. Lee County School Board
10. St Johns County School Board
11. DMS
12. DEMS
13. City of Daytona Beach
14. Key West Electrical Co-Op

15. Tarpon Springs
16. Punta Gorda
17. Sarasota County
18. Orange County Convention Center
19. City of Casselberry
20. Manatee County

Below is a list of Employees and procedure:

1. Sonny J Dukes, President, Lead Industrial Tech, 6σ 407.280.7904
2. Shannon M Dukes VP, PMP, MBA 352.735.8285
3. Jack Phillips, EC Qualifier 727.858.0687
4. David Kornstadt, Commercial AE 352.805.5024
5. Haley Bogart AR/AP 352.735.8285
6. Brian Eakin, Operations Manager – 352.735.8285
7. Brian Eakin, Lead/Certified Industrial Technician 352.735.8285
8. Chris Ethridge – Lead Engineering and Senior Electrician, Lic Journeyman, Estimator.
9. Kim Slotnick – Project Coordinator 352.735.8285
10. Toni Hayden, Service Manager, Parts, Warranty and Commercial 352.735.8285
11. Allen Green – Lead Industrial Technician/Trainer 352.735.8285
12. On-Call 352.735.8285

We are currently staffed to complete 10 million in Revenue annually. **Our service department supports some large clients to date such as the City of Eustis, Mt Dora, Lake County, and Department of Transportation. We also support several “Life Safety” Clients such as nursing homes and assisted living facilities.** All 30 of our Vehicles are 2020-2022 and are either owned by us or Enterprise Fleet. Our Company was started in 2005 and has over 3500 Residential, Commercial, and Industrial Clients.

Accurate Power and Technology is open Monday thru Friday from 0800 to 1730

Accurate Power and Technology, Inc Currently employees 48 individuals from Permit Technicians, Service Technicians to Electrical Installation Technicians.

Accurate Power and Technology resides in Eustis, Fl housing around 5000sqr/ft of rented space. We also own free and clear an acre of property in Mt Dora located

on 441 where we intend to build the future office. Both are secure and house cameras.

Accurate Power holds Brick and Mortar in Eustis, and Sarasota

Accurate Power and Technology can accommodate walk-ins and scheduled appointments. We can usually respond to appointment requests and accommodate most any time and date during normal day and times.

When emergencies arise Accurate Power and Technology will ensure The School District is given priority for repair and call outs.

Our Uniformed techs are completely qualified and have the tools on hand to complete most of the work that would be needed. EX..

1. Air Tools and Compressors.
2. Pumps.
3. Safety Clean supply's our Oil and AF.
4. Welders
5. Calibrated Meters and complete PPE
6. We are building a truck to carry Fuel 200 gallons for emergencies.
7. Torque wrenches
8. Laptop and software for ATS's and Engine Diagnostic Tools.
9. 500KW and 6-100KW Load Banks in inventory. The Upper Sizes are rented to 2M.
10. Fuel Testing (Polaris Labs)
11. Fuel Polishing (In House)
12. OSHA 10-40, NFPA110 training held in house. Certified Trainer

All contents of this proposal are true and accurate.

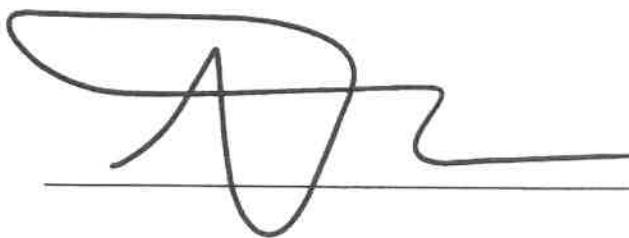
A handwritten signature in black ink, consisting of a large, stylized initial 'A' followed by a horizontal line and a small flourish.

President 11/20/2024



Ron DeSantis, Governor

Melanie S. Griffin, Secretary



STATE OF FLORIDA DEPARTMENT OF BUSINESS AND PROFESSIONAL REGULATION

ELECTRICAL CONTRACTORS' LICENSING BOARD

THE ELECTRICAL CONTRACTOR HEREIN IS CERTIFIED UNDER THE
PROVISIONS OF CHAPTER 489, FLORIDA STATUTES



Additional Business Qualification

PHILLIPS, JACK E

A GENERATOR GUY
32744 SCENIC HILLS DRIVE
MOUNT DORA FL 32757

LICENSE NUMBER **EC13007737**

EXPIRATION DATE: **AUGUST 31, 2026**

Always verify licenses online at MyFloridaLicense.com

ISSUED: 07/02/2024

Do not alter this document in any form.

This is your license. It is unlawful for anyone other than the licensee to use this document.



**EVALUATION OF PAST PERFORMANCE –
ENCLOSE THREE (3) REFERENCES WITH THE BID**
(Please type or clearly print below)

To be completed by the Bidder:

Bidder or Associated Business Entity's Name: Accurate Power and Technology
Company Representative: Chris Eldrige
Bidder's Phone Number: 352 735-8285

REFERENCE:

Reference Organization Name: City of Winter Springs
Reference Contact: Leonard Hartman
Reference Phone Number: 407 327-7580
Reference Email Address: Lhartman@winterspringsfl.org

Briefly describe the work performed for the above Reference:
Installed 26 light poles and LED Lights.

The following questions will be asked of the client reference as chosen at the discretion of the Department.

1. How well did the contractor adhere to the agreed upon schedule?

Excellent XX Above Satisfactory _____ Satisfactory _____ Fair _____
Poor _____

Comments: Contractor met each deadline.

2. How would you rate the contractor's overall quality of work?

Excellent XX Above Satisfactory _____ Satisfactory _____ Fair _____
Poor _____

Comments: Contractor did a great job.

3. How would you rate the contractor's use of adequate personnel in quantity, experience and professionalism?

Excellent XX Above Satisfactory _____ Satisfactory _____ Fair _____
Poor _____

Comments:

4. How would you rate the contractor's use of appropriate equipment and methods?

Excellent XX Above Satisfactory _____ Satisfactory _____ Fair _____
Poor _____

SCORING:

Excellent	=	4	4 points	
Above Satisfactory	=		3 points	Total Score = <u>16</u>
Satisfactory	=		2 points	
Fair	=		1 point	
Poor	=		0 points	Average (Total Score/4) = <u>4</u>

Reference Signature: Len Hartman Date: 2024-10-31

3.3 BUSINESS REFERENCES

The Proposer must submit at least **THREE (3) REFERENCES WITH THE SUBMITTED PROPOSAL**. HCPS may contact these references to predict the quality of goods and services. False references, in HCPS' sole discretion, may be cause for Proposer's disqualification. **DO NOT IDENTIFY HCPS AS A REFERENCE.**

- Included references should be customers from the previous three (3) years; and
- HCPS-Preferred references shall be in the following order: School districts, Hillsborough County, Florida based references, State of Florida based references, Large municipalities or local governments, and the private sector.

In response to this Hillsborough County Public Schools' competitive solicitation, Proposer (Proposer Name):

Accurate Power and Technology, Inc states that they have provided similar goods and services to your firm. Please respond as to the quality of the provided goods and services. Return this form as soon as possible to the firm for proposal submission. The filled-in references are due with their proposal.

Pinellas County Schools
 Referred Firm's Name

11111 S. Belcher RD. Largo. FL 33773
 Address

Mike McClimon
 Contact Person

mcclimonm@pcsb.org 727.638.3373
 Email Address Phone Number

X Yes No: Would you use this contractor again?
 X Yes No: May we contact you with additional questions?
 Total Dollar Amount of Contract: \$350,000.00

Performance Rating: Excellent = 4, Good = 3, Fair = 2, Poor= 1, or N/A

DESCRIPTION OF PERFORMANCE

	RATING
Overall Technical Performance. The Contractor's overall demonstrated technical performance.	<u>4</u>
Partnership. The Contractor's ability and attention to the quality of outcomes.	<u>4</u>
Responsiveness. The Contractor's ability to follow instructions, handle complaints, and communicate with custom staff.	<u>4</u>
Efficiency. The Contractor's overall effectiveness in planning, scheduling, monitoring, and problem-solving.	<u>4</u>
Uniformity of Goods/Service Reliability. The Contractor's timely delivery and uniform quality of provided goods and services.	<u>4</u>
Key Personnel/Management. The Contractor's ability to provide quality personnel and project oversight.	<u>4</u>
Overall Experience. Overall customer experience.	<u>4</u>

Additional Comments.
Great service, always there for emergencies. Keeps in contact about repairs and parts orders.

mike mcclimon 07/22/2024
 Contact Person Signature Date

**EVALUATION OF PAST PERFORMANCE –
ENCLOSE THREE (3) REFERENCES WITH THE BID**

(Please type or clearly print below)

To be completed by the Bidder:

Bidder or Associated Business Entity's Name: _____

Company Representative: _____

Bidder's Phone Number: _____

REFERENCE:

Reference Organization Name: Manatee County School District

Reference Contact: Steve Gill

Reference Phone Number: 941-932-7912

Reference Email Address: Gills@manateeschools.net

Briefly describe the work performed for the above Reference:

Generator install

The following questions will be asked of the client reference as chosen at the discretion of the Department:

1. How well did the contractor adhere to the agreed upon schedule?

Excellent Above Satisfactory _____ Satisfactory _____ Fair _____ Poor _____

Comments: _____

2. How would you rate the contractor's overall quality of work?

Excellent Above Satisfactory _____ Satisfactory _____ Fair _____ Poor _____

Comments: _____

3. How would you rate the contractor's use of adequate personnel in quantity, experience and professionalism?

Excellent Above Satisfactory _____ Satisfactory _____ Fair _____ Poor _____

Comments: _____

4. How would you rate the contractor's use of appropriate equipment and methods?

Excellent Above Satisfactory _____ Satisfactory _____ Fair _____ Poor _____

Comments: _____

SCORING:

Excellent = 4 points

Above Satisfactory = 3 points

Satisfactory = 2 points

Fair = 1 point

Poor = 0 points

Total Score = 16

Average (Total Score/4) = 16

Reference Signature: _____

Date: 10/28/24

ATTACHMENT - 3

REFERENCE FORM

	The School Board of Seminole County, Florida Purchasing and Distribution Services Department 400 East Lake Mary Boulevard Sanford, Florida 32773
The Next Line To Be Completed by the Firm Being Referenced: Firm: <u>Lee County Schools</u>	
School Board ITB Number and Title. ITB #20210058B-CB – Generator P.M. and Repair	

The School Board of Seminole County is currently evaluating qualifications of various firms to provide the above professional contract services and the indicated firm has listed you as a reference, having performed similar services for your organization. Please take a few moments to complete the following survey and return to firm requesting reference. Your assistance in providing this information is appreciated. *Reference forms shall be included in your bid submittal.

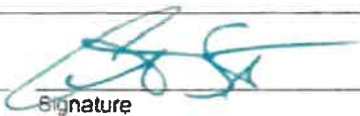
This Section To Be Completed by the Reference Provider:	
What specific services did this firm provide? <u>Generator PM and Service Contract</u>	
Was the firm responsive to your needs and requests?	<input checked="" type="checkbox"/> Yes <input type="checkbox"/> No
Was there good communication between the client and the firm?	<input checked="" type="checkbox"/> Yes <input type="checkbox"/> No
Was the firm proactive in resolving problems and disputes?	<input checked="" type="checkbox"/> Yes <input type="checkbox"/> No
Was the staff professional and knowledgeable?	<input checked="" type="checkbox"/> Yes <input type="checkbox"/> No
Were the services completed on time and within budget?	<input checked="" type="checkbox"/> Yes <input type="checkbox"/> No
Has this firm ever been awarded a repeat contract by your Organization for similar services?	<input checked="" type="checkbox"/> Yes <input type="checkbox"/> No
Would you award a contract to this firm again for similar services?	<input checked="" type="checkbox"/> Yes <input type="checkbox"/> No
How would you rate the overall performance of the firm? <input checked="" type="checkbox"/> Excellent <input type="checkbox"/> Very Good <input type="checkbox"/> Satisfactory <input type="checkbox"/> Unsatisfactory	
Comments: <u>Accurate Power has provided EXCELLENT SERVICE TO OUR school District WE value our Partnership!</u>	
Name of Person Providing Information: <u>Christopher Steuser</u>  Printed name Signature	
Title: <u>MAINTENANCE Coordinator</u>	Phone: <u>(239) 785-6368</u>
Company/Agency: <u>LEE COUNTY School District (LCSD)</u>	Date: <u>2-20-24</u>



PROPOSAL

IPS Power Systems

6312 78th street
Riverview, Florida 33578
www.ips.us

TOTAL NET VALUE

Accurate Power & Technology

15519 West Highway 441, Suite 101A
Eustis, FL 32726

Proposal #
Proposal Date
Project
Contact
Expires
Mobile Number :
Branch
Address

Attention:

ITEM & DESCRIPTION

AMOUNT

KOHLER Model 40REOZK , EPA Certified Diesel Generator Set
40kW, @ 1.0 PF, 60 Hz, 1 Phase, 120/240 Volt

APM402 Controller

Enclosure: Sound Attenuated Aluminum
- 186 MPH Wind Load Rated

Sub-base Fuel Tank, 72 Hour, 275 Gallon, UL142
- Fuel Water Separator, Flexible Fuel Lines

Line Circuit Breaker, 3 Pole, 100% Rated,
- 200 amp, Thermal Mag w/ Shunt Trip, Shunt Trip Wiring

Block Heater 120 Volt, 1000 Watt
Generator Heater
Battery Rack and Cables
Starting Battery, Lead Acid
Battery Charger: 10 Amps
Remote Emergency Stop, Lockable

Automatic Transfer Switch:
- None

Certified Factory Test @ 0.8 P.F.
1 Engine, Generator Parts, Maintenance Manuals & 1 Electronic Manual
Vibration Isolators: Internal

Warranty and Services:



ITEM & DESCRIPTION

AMOUNT

Five Year Warranty
Start Up
On Site Load Bank Testing
Owner Training

Supplied by Others:
Off-loading @ Job Site
Installation of System
Fuel & Electrical Piping
All Infrared, 3rd Party & NETA Testing
Supply of Fuel

Estimated Lead Time:
18 weeks after release of order
Please note: The lead time provided represents the most current factory lead times and is subject to change at the time of order release

Exceptions / Clarifications / Notes:
1.)

Offer Based Upon:
Information provided

Note:
Delivery, Start up, and Load testing are quoted as during normal business hours. If after hours, weekend, or holiday work hours are required, the Contractor will be responsible for the overtime differential unless otherwise noted

Total Net Value

F.O.B. Factory
Freight Allowed To Job Site
Sales Tax Not Included

Tariff Surcharge – please note this quote is subject to a tariff surcharge which will be estimated based on the current tariff environment. The final tariff surcharge will be updated at the time of invoicing.

Terms & Conditions

TAW Power Systems, Inc. STANDARD TERMS and CONDITIONS apply to all offers for purchase and any purchase orders accepted by TAW Power Systems, Inc. You may find a copy under the terms and conditions section at tawinc.com or please contact our office at 800-456-9449 and we will forward you a copy. TAW Power Systems, Inc. will transmit a written delivery schedule based on the manufacturer's confirmation, approximately fifteen (15) days after product release. Also included will be the related progress invoice values based on material shipments.

All TAW Power Systems, Inc. offers, plans, specifications, and technical drawings are copyrighted works and contain proprietary know-how of TAW Power Systems, Inc. and Buyer has no right to reproduce, distribute or publish copies of TAW Power Systems, Inc's copyrighted works or to create derivative works of TAW Power Systems, Inc. copyrighted works without the express written permission of an authorized representative of TAW Power Systems, Inc.

Offer Acceptance Signature _____



ISO 9001
KOHLER
POWER SYSTEMS
NATIONALLY REGISTERED



MPAC® 500 Controller Features

- User-friendly interface with easy-to-read international symbols
- Source available and contactor position indicators
- LED indication of system faults
 - Failure to acquire standby source
 - Failure to transfer
 - Auxiliary switch fault
- Common fault contact: latches closed on system faults shown above
- Engine start contact: provides contact closure to start the generator set
- Load control contact: allows 5-minute delay in startup of selected loads
- Test button (with or without load)
- Exercise set button
 - Weekly 20-minute generator set exercise
 - With or without load
- Single-phase voltage sensing on both sources, $\pm 5\%$
- Line-to-line frequency sensing, $\pm 2\%$
- Fixed time delays

Standard Features

- UL listed
 - UL 1008 listed, file #E58962
 - Models with load centers use UL 67 listed components
- cUL listed
 - 100 and 200 amp models with load centers
- CSA certification available, file #LR58301 (not applicable to service entrance or load center models)
- 220/240 VAC, 50/60 Hz (selectable)
- 100, 200, and 400 amp models available
- Two-pole, single-phase open-transition transfer switch
- Contactor electrically and mechanically interlocked
- Double throw inherently interlocked design
- Solid neutral
- Contactor manually operable for maintenance purposes
- Silver alloy main contacts
- All models are 100% equipment rated and can be applied at the rated current without derating
- 100 and 200 amp models available with or without prewired Square D type QO load center
 - 100 amp load center models use up to 16 circuit breakers (up to 8 tandem breakers can be used for a maximum of 24 circuits)
 - 200 amp load center models use up to 24 circuit breakers
 - 200 amp service entrance model with 42-circuit breaker load center is available
- Two enclosures available
 - NEMA Type 1 steel ANSI 49 gray enclosure for indoor installation. 100 amp and 200 amp models without load centers can be recess-mounted between wall studs (not service entrance model)
 - NEMA Type 3R corrosion-resistant aluminum ANSI 49 gray padlockable enclosure. Approved for indoor or outdoor installation
- Five-year limited warranty
- See page 5 for available accessories

Service Entrance Model Features

- 200 and 400 amp service entrance rated automatic transfer switches available
- Service disconnect circuit breaker on the normal (utility) source (80% rated)
- NEMA 3R aluminum ANSI 49 gray enclosure
- Circuit breaker for generator set battery charger
- See page 5 for available SE model accessories

Environmental Specifications	
Operating temperature:	- 20°C to 70°C (- 4°F to 158°F)
Storage temperature:	- 40°C to 85°C (- 40°F to 185°F)
Humidity:	5 to 95% noncondensing

Contact Ratings	
Engine start	0.5 A @ 125 VAC; 2 A @ 30 VDC SPST normally closed (NC)
Common fault	0.5 A @ 125 VAC; 2 A @ 30 VDC SPST normally open (NO)
Load control	10 A @ 120 VAC SPST normally open (NO)
Auxiliary contacts (optional)	15 A @ 277 VAC Form C

Source Sensing	
Undervoltage dropout	80%
Undervoltage pickup	85%
Underfrequency dropout	90%
Underfrequency pickup	96%

Time Delays			
Time Delay	Factory Setting	Adjustment with Accessory Board*	
		Range	Increment
Engine start	3 seconds	1-10 seconds	1 second
Transfer from Normal to Emergency	3 seconds	1-10 seconds	1 second
Retransfer from Emergency to Normal	6 minutes	3-30 minutes	3 minutes
Engine cooldown	5 minutes	1-10 minutes	1 minute
Exercise run time	20 minutes	5-50 minutes	5 minutes
Exercise interval	1 week	1 week/2 week (DIP switch)	
Load control connection delay	5 minutes	5 or 10 minutes (DIP switch)	
Failure to acquire Emergency source	78 seconds	NA	
Undervoltage dropout	0.5 second	NA	
Underfrequency dropout	3 seconds	NA	

* Optional accessory board required for time delay adjustments
NA = not adjustable

Cable Sizes					
AL/CU UL-Listed Solderless Screw-Type Terminals for External Power Connections					
Switch Size, Amps	Range of Wire Sizes, Cu/Al				
	Normal (per phase)	Emergency (per phase)	Load (per phase)	Neutral	Ground
100	(1) #14 - 1/0 AWG	(1) #14 - 1/0 AWG	(1) #14 - 1/0 AWG	(5) #12 - 250 MCM (Cu) or (5) #10 - 250 MCM (Al)	(9) #14 - #6 AWG (4) #14 - 1/0 AWG
100 B	(1) #14 - 1/0 AWG	(1) #14 - 1/0 AWG	per customer-supplied branch circuit breakers	(26) #14 - #4AWG or (2) #14 - 1/0 AWG or (1) #6 - 2/0 AWG	
200	(1) #6 AWG - 250 MCM	(1) #6 AWG - 250 MCM	(1) #6 AWG - 250 MCM	(5) #12 - 250 MCM (Cu) or (5) #10 - 250 MCM (Al)	
200 B	(1) #6 AWG - 250 MCM	(1) #6 AWG - 250 MCM	per customer-supplied branch circuit breakers	(38) #14 - #4 AWG or (3) #14 - 1/0 AWG or (1) #4 AWG - 250 MCM	
200 BSE	(1) #4 - 300 MCM	(1) #6 - 250 MCM	per customer-supplied branch circuit breakers	(4) #12 - 250 MCM (Cu) or (4) #10 - 250 MCM (Al)	(9) #14 - #6 AWG (4) #14 - 1/0 AWG
200 SE	(1) #4 - 300 MCM	(1) #6 - 250 MCM	(1) #6 AWG - 250 MCM	(5) #12 - 250 MCM (Cu) or (5) #10 - 250 MCM (Al)	
400	(2) #6 - 250 MCM	(2) #6 - 250 MCM	(2) #6 - 250 MCM	(3) #4 - 600 MCM (6) 1/0 - 250 MCM	(6) #6 - 3/0 AWG
400 SE	(1) #1 - 600 MCM or (2) #1 - 250 MCM	(2) #6 - 250 MCM	(2) #6 - 250 MCM	(3) #4 - 600 MCM (6) 1/0 - 250 MCM	

B = Load center model
SE = Service entrance model

Note: Data is subject to change. Refer to the transfer switch dimension drawings and wiring diagrams for planning and installation.

Contactor Ratings with Coordinated Circuit Breakers

The transfer switches are UL listed at 240 VAC maximum. The following table lists contactor withstand current ratings (WCR) for 100- 400 ampere non-service entrance rated switches with specific manufacturer's circuit breakers per UL and Canadian safety standards. Suitable for control of motors, electric discharge lamps, tungsten filament lamps and electric heating equipment where the sum of motor full-load ampere ratings and the ampere ratings of other loads do not exceed the ampere rating of the switch and the tungsten load does not exceed 30 percent of switch rating.

WCR Ratings with Specific Manufacturer's Molded-Case Circuit Breakers					
Switch Rating, Amps	Voltage, max.	WCR, RMS Symmetrical Amps	Manufacturer	Type or Class	Maximum Size, Amps
100	240	10,000	Any Breaker *	Any Breaker (0.025 seconds max.)	—
200	240	10,000	Any Breaker *	Any Breaker (0.025 seconds max.)	—
400	240	35,000	ABB	T5, T6	600
			Eaton	CHKD, CKD, DK, HKD, KD, KDB, KDC, LA TRIPAC, LCL	400
				CHLD, CLD, CLDC, HLD, LD, LDB, LDC	600
				HMDL, MDL, NB TRI- PAC	800
			General Electric	FGH, FGL, FGN, FGP, SGHA	600
			Merlin Gerin	CJ400H, CJ400L, CJ400N	400
				CJ600H, CJ600N	600
			Siemens	CJD6, HHJD6, HHJXD6, HJD6, HJGA, HJXD6, JD6, JXD2, JXD6, SCJD6, SHJD6, SJD6, NJGA, LJGA	400
				CLD, HHL, HHLXD, HLD, HLGA, HLXD, LD, LLGA, LXD, NLGA, SCLD, SHLD, SLD	600
				CMD, HLMD, HLMXD, HMD, HMG, HMXD, LMD, LMG, LMXD, MD, MXD, NMG, SCMD, SHMD, SMD	800
			Square D	LA, LC, LE, LH, LI, LX, LXI	400
		DG, DJ, DL, LC, LE, LI, LX, LXI		600	
		50,000	Eaton	LD	600

* For higher WCR values, contact the factory for additional specific breaker ratings.

Service Entrance Transfer Switch Ratings

The service entrance transfer switch is factory-equipped with a normal source disconnect circuit breaker.

Switch Rating, Amps	WCR, RMS Symmetrical Amps at 240 VAC
200	22,000
400	35,000

Codes and Standards

The ATS meets or exceeds the requirements of the following specifications:

- Underwriters Laboratories UL 1008, Standard for Automatic Transfer Switches for Use in Emergency Systems, file #E58962
- Underwriters Laboratories UL 508, Standard for Industrial Control Equipment
- CSA certified, file #LR58301 (not applicable to service entrance models)
- NFPA 70, National Electrical Code
- NFPA 110, Emergency and Standby Power Systems
- IEEE Standard 446, IEEE Recommended Practice for Emergency and Standby Power Systems for Commercial and Industrial Applications
- NEMA Standard IC10- 1993 (formerly ICS2- 447), AC Automatic Transfer Switches
- ANSI C37.90.1 (IEEE472), 2000, EFT/Surge Relay Systems
- EN61000-4-5 Surge Immunity Class 4 (voltage sensing and programmable inputs only)
- EN61000-4-4 Fast Transient Immunity Severity Level 4
- IEC Specifications for EMI/EMC Immunity
 - CISPR 11, Radiated and Conducted Emissions, Class B
 - IEC 61000-4-2, 2001, Electrostatic Discharge
 - IEC 61000-4-3, 2002, Radiated Immunity
 - IEC 61000-4-4, 2001, Electrical Fast Transients (Bursts)
 - IEC 61000-4-5, 2001, Surge Voltage Immunity
 - IEC 61000-4-6, 2003, Conducted RF Immunity
 - IEC 61000-4-8, Magnetic Field Immunity
 - IEC 61000-4-11, Voltage Dips and Interruptions

Weights and Dimensions

Note: Always use the transfer switch dimension drawing for planning and installation. Weights and dimensions may vary for different configurations. See the Operation/Installation Manual or your local distributor for dimension drawings.

Transfer switch weights and dimensions shown in the table do not include packaging. To estimate the shipping weight, add 3 kg (5 lbs.) or 10% (whichever is larger) to the weight shown.

Amps	Load Center	Enclosure Type	Weight		Transfer Switch Dimensions		Dimension Drawing
			kg	(lb.)	H x W x D, mm (in.)		
100	None	NEMA 1 (steel)	7	(15)	610 x 330 x 154 *	(24.0 x 13.0 x 6.0) *	ADV-8437
100 B	16 circuits		18	(40)	914 x 406 x 154	(36.0 x 16.0 x 6.0)	ADV-9181
200	None		7	(15)	610 x 330 x 154 *	(24.0 x 13.0 x 6.0) *	ADV-8438
200 B	24 circuits		21	(45)	914 x 406 x 154	(36.0 x 16.0 x 6.0)	ADV-9182
400	None	NEMA 1 (aluminum)	40	(89)	1067 x 560 x 269	(42.0 x 22.0 x 10.6)	ADV-8439
100	None	NEMA 3R (aluminum)	7	(15)	613 x 340 x 177	(24.1 x 13.4 x 7.0)	ADV-8440
100 B	16 circuits		8	(18)	917 x 416 x 177	(36.1 x 16.4 x 7.0)	ADV-9183
200	None		7	(15)	613 x 340 x 177	(24.1 x 13.4 x 7.0)	ADV-8441
200 B	24 circuits		8	(18)	917 x 416 x 177	(36.1 x 16.4 x 7.0)	ADV-9184
200 SE	None		12	(26)	858 x 473 x 163	(33.8 x 18.6 x 6.4)	ADV-8444
200 BSE	42 circuits		32	(70)	967 x 762 x 165	(38.1 x 30.0 x 6.5)	ADV-9185
400	None		40	(89)	1067 x 560 x 269	(42.0 x 22.0 x 10.6)	ADV-8439
400 SE	None		46	(101)	1067 x 560 x 269	(42.0 x 22.0 x 10.6)	ADV-8445

B = Load center model
SE = Service entrance model

* Can be recess-mounted between 16 in. O.C. wall studs.

Accessories

Auxiliary position-indicating contacts

- One closed on normal position and one closed on emergency position
- Form C contacts rated 15 A @ 250 VAC

Accessory board

- Alarm horn indicates system faults
- Adjustable time delays:
 - Engine start
 - Engine cooldown
 - Preferred to standby
 - Standby to preferred
 - Exercise duration
- Inputs and Outputs:
 - Remote start/stop input (loaded)
 - Programmable exerciser input
 - Generator set supplying load output: 10 A @ 120 V SPST normally open (NO) contact
- External alarm module connection
- Dip switches:
 - 1 week/2 week exerciser
 - Load/no load exercise mode (for optional programmable exerciser)
 - Momentary/maintained external start/stop input: Selects momentary (1 second) push button or maintained contact closure for remote start/stop signal
 - Load control, 5 minutes/10 minutes: Allows adjustment of the startup delay after transfer to generator set for selected loads (e.g. air conditioners or other large motor starting loads)
 - Audible alarm disable

External alarm module

- Alarm horn
- Alarm silence/lamp test button
- Remote start/stop button
- Generator supplying load indicator
- Fault indicator
- Fits into standard outlet box
- Multiple alarm modules can be connected
- Accessory board required

Load shed kit

- Automatically sheds non-critical loads when essential appliances are running
- Prevents generator overload in compliance with NEC 2008
- Provides two (2) HVAC relays, rated 10 A @ 125 VAC, to control two independent air conditioner loads
- Includes four (4) pilot relays rated 120VAC, 125VA (pilot duty), 10 A @ 125 VAC (general purpose) to control customer-provided power relays for non-essential loads
- Mounts inside the ATS enclosure
- Uses Kohler's exclusive RBUS communication protocol
- Requires Kohler® residential generator set with RDC2 or DC2 controller
- See specification sheet G11-124

Power relay modules

- 50 amp power relay mounted in a NEMA Type 3R enclosure
- Use up to four modules with the load shed kit
- UL/cUL listed
- Dimensions: 172 x 233 x 92 mm (6.8 x 9.2 x 3.6 in.)
- For more information, see specification sheet G6-143

Programmable exerciser

- Seven-day programmable timer allows scheduling up to 56 on/off events
- LCD display indicates day, time, program/run modes, and on/off/skip status
- Skip next cycle button
- Lithium backup battery with 5-year expected life
- Accessory board required

Wall-mount bezel (for Type 1 enclosures)

- For 100 and 200 amp recess-mounted switches
- For NEMA type 1 enclosures only (not for NEMA 3R or service entrance switches)

Additional Accessories for Service Entrance Models

Accessory circuit breaker

- For generator set engine heater or other AC accessory
- 15 A single-pole Square D type QO circuit breaker

Enclosure space heater

- 150 Watts
- Hygrostat (humidity control)
- Built-in temperature limiter for overheat protection
- 15 A single-pole Square D type QO circuit breaker

Utility-side surge suppressor

- Surge protection reduces transient voltages to harmless levels
- Protection modes: L-L / L-N / L-G / N-G
- Replaceable phase and neutral cartridges for service
- Frequency: 50-60 Hz
- Operating Temperature Range: -40 to 176°F (-40 to 80°C)
- Remote contacts for customer-supplied status indicators:
 - Contacts: 1 NO, 1 NC
 - Min Load: 12VDC / 10 mA
 - Max. Load: 250 VAC / 1 A
 - Wire Size (max.): 16AWG
- Fuse protection: 30 amps / 600 V
- UL 1449, 3rd Edition for Type 2 applications
- IEC 61-643-1, 2nd Edition T2/11
- See additional specifications below

Surge Suppressor Specifications

Nominal Voltage (V ±15%)	Max. Discharge Current (kA)	Phase	Poles	UL VPR 3rd Ed (L-N/N-G/L-G) (kV)	Limiting Voltage, (L-N/N-G/L-G) (kV)		Short Circuit Withstand Current (kA)	Maximum Continuous Operating Voltage (VAC)
					at 3kA	at 10kA		
240/120	40	Split	3	0.6 / 1.2 / 0.7	0.6 / 0.4 / 0.6	0.8 / 0.7 / 0.8	200	175 / 350

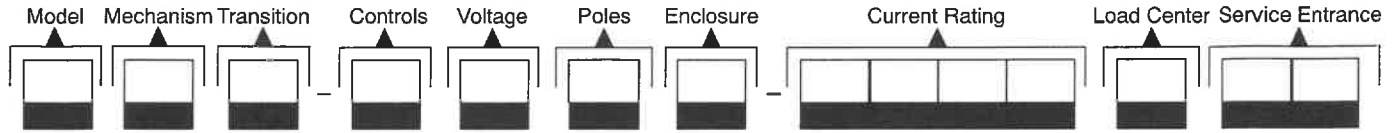

Kohler® Model Designation Key

This chart explains the Kohler® transfer switch model designation system. The sample model designation shown is for a Model R service entrance rated automatic transfer switch that uses a standard-transition contactor with MPAC® 500 electrical controls rated at 240 Volts/60 Hz with 2 poles, 3 wires, and solid neutral in a NEMA 3R enclosure with a current rating of 200 amperes and no load center.

SAMPLE MODEL DESIGNATION

RDT-CFNC-0200ASE

Model

R: Model R automatic transfer switch

Mechanism

D: Specific-breaker rated

Transition

T: Standard transition

Electrical Controls

C: MPAC® 500 (Microprocessor ATS Control)

Voltage/Frequency

D: 220 Volts/50 Hz
 F: 240 Volts/60 Hz

Number of Poles/Wires

N: 2-pole, 3-wire, solid neutral

Enclosure

A: NEMA 1 (steel) *
 C: NEMA 3R (aluminum)

Current Rating: Numbers indicate the current rating of the switch in amperes:

0100: 100 amps 0200: 200 amps 0400: 400 amps

Load Center

A: Without load center
 B: With load center (not available on 400 Amp models)

Service Entrance:

SE: Service entrance model (200 and 400 Amp models available)
 Blank: Not rated for service entrance

* NEMA 1 only: 100 and 200 amp models without load centers can be recess-mounted between wall studs. Optional wall-mount bezel available. The NEMA 1 enclosure for 400 amp models is aluminum.

DISTRIBUTED BY:

Availability is subject to change without notice. Kohler Co. reserves the right to change the design or specifications without notice and without any obligation or liability whatsoever. Contact your local Kohler® generator distributor for availability.

Town of Ponce Inlet RFP Form

Public Works Emergency Generator

REQUEST FOR PROPOSAL #2025-02 (RFP #2025-02)

Scope of Work:

The Town of Ponce Inlet is requesting a proposal for an emergency generator for the Public Works compound located at 4875 South Peninsula Drive, Ponce Inlet Florida 32127. Proposals shall be submitted based on the purchase, installation, and integration of a 40Kw standby generator. The 40Kw generator can be either diesel or propane powered.

The Generator will be relocated on site to accommodate the addition of a new building. The main electrical service to the compound and transfer switch will need to be relocated as part of this project to also accommodate the addition of a new building. Activities will be completed in strict compliance with Federal, State and Local Codes and Regulations.

The Generator shall be designed/constructed/installed in accordance with the 2023 Florida Building Code and 2020 NEC.

The contractor will be responsible for the permit and engineering to move the main electrical feed and transfer switch to install and integrate the generator into the Public Works main building. After completion of the integration of the generator the contractor will provide a one-hour training session about the generator for Public Works staff.

Deadline:

Please return this Request for Proposal Form addressed to Town Clerk, Town of Ponce Inlet, 4300 S. Atlantic Avenue, Ponce Inlet, FL 32127 in a SEALED ENVELOPE plainly marked on the outside "**RFP 2025-02 Public Works Emergency Generator**" with a Lump Sum Price by **2:00 pm, Friday, February 28, 2025.**

Lump Sum/Unit Pricing:

ITEM NO.	DESCRIPTION	EST QUANTITY	UNIT	AMOUNT PROPOSAL
1	40Kw Generator	1	LS	\$80,038.61
2	Move main power feed	1	LS	\$20,000.00
3	Alternate for New Transfer Switch	1	LS	Included in generator pricing
LUMP SUM TOTAL				\$100,038.61

NOTE: This is for LUMP SUM COST of the entire project, unit prices are to establish pricing if additional work is required above or beyond the Lump Sum Base Price.

Vendor Name:	Town of Ponce Inlet	Date:	2/26/2025
Company:	Zabatt Engine Services, Inc.		
Phone #:	904-384-4505	eMail:	sales@zabatt.com / bids@zabatt.com
Signature:		Print Name:	Sandra M. Sabatier

Attachment F
Certification Regarding
Debarment, Suspension, Ineligibility
And Voluntary Exclusion

Subcontractor Covered Transactions

- (1) The prospective subcontractor, Zabatt Engine Services, Inc., of the Recipient certifies, by submission of this document, that neither it nor its principals is presently debarred, suspended, proposed for debarment, declared ineligible, or voluntarily excluded from participation in this transaction by any Federal department or agency.
- (2) Where the Recipient's subcontractor is unable to certify to the above statement, the prospective subcontractor shall attach an explanation to this form.

SUBCONTRACTOR:

Zabatt Engine Services, Inc.

By 
 Signature

Town of Ponce Inlet
 Recipient's Name

Sandra M. Sabatier
 Name and Title

 DEM Contract Number

4612 Highway Avenue
 Street Address

2025-02-0-2025
 Project Number

Jacksonville, FL 32254
 City, State, Zip

2/26/2025
 Date

1

Request for Taxpayer Identification Number and Certification

Go to www.irs.gov/FormW9 for instructions and the latest information.

**Give form to the
requester. Do not
send to the IRS.**

Before you begin. For guidance related to the purpose of Form W-9, see *Purpose of Form*, below.

Print or type. See Specific Instructions on page 3.	1 Name of entity/individual. An entry is required. (For a sole proprietor or disregarded entity, enter the owner's name on line 1, and enter the business/disregarded entity's name on line 2.) Zabatt Engine Services, Inc.	
	2 Business name/disregarded entity name, if different from above. dba / Zabatt, Inc. and dba / Zabatt Power Systems, Inc.	
	3a Check the appropriate box for federal tax classification of the entity/individual whose name is entered on line 1. Check only one of the following seven boxes. <input type="checkbox"/> Individual/sole proprietor <input type="checkbox"/> C corporation <input checked="" type="checkbox"/> S corporation <input type="checkbox"/> Partnership <input type="checkbox"/> Trust/estate <input type="checkbox"/> LLC. Enter the tax classification (C = C corporation, S = S corporation, P = Partnership) Note: Check the "LLC" box above and, in the entry space, enter the appropriate code (C, S, or P) for the tax classification of the LLC, unless it is a disregarded entity. A disregarded entity should instead check the appropriate box for the tax classification of its owner. <input type="checkbox"/> Other (see instructions)	
	4 Exemptions (codes apply only to certain entities, not individuals; see instructions on page 3): Exempt payee code (if any) <u>5</u> Exemption from Foreign Account Tax Compliance Act (FATCA) reporting code (if any)	
	3b If on line 3a you checked "Partnership" or "Trust/estate," or checked "LLC" and entered "P" as its tax classification, and you are providing this form to a partnership, trust, or estate in which you have an ownership interest, check this box if you have any foreign partners, owners, or beneficiaries. See instructions <input type="checkbox"/> <i>(Applies to accounts maintained outside the United States.)</i>	
	5 Address (number, street, and apt. or suite no.). See instructions. 4612 Highway Avenue	Requester's name and address (optional)
	6 City, state, and ZIP code Jacksonville, FL 32254	
7 List account number(s) here (optional)		

Part I Taxpayer Identification Number (TIN)

Enter your TIN in the appropriate box. The TIN provided must match the name given on line 1 to avoid backup withholding. For individuals, this is generally your social security number (SSN). However, for a resident alien, sole proprietor, or disregarded entity, see the instructions for Part I, later. For other entities, it is your employer identification number (EIN). If you do not have a number, see *How to get a TIN*, later.

Social security number	
-	
-	
or	
Employer identification number	
5	9
-	1
8	8
9	2
7	1

Note: If the account is in more than one name, see the instructions for line 1. See also *What Name and Number To Give the Requester* for guidelines on whose number to enter.

Part II Certification

Under penalties of perjury, I certify that:

1. The number shown on this form is my correct taxpayer identification number (or I am waiting for a number to be issued to me); and
2. I am not subject to backup withholding because (a) I am exempt from backup withholding, or (b) I have not been notified by the Internal Revenue Service (IRS) that I am subject to backup withholding as a result of a failure to report all interest or dividends, or (c) the IRS has notified me that I am no longer subject to backup withholding; and
3. I am a U.S. citizen or other U.S. person (defined below); and
4. The FATCA code(s) entered on this form (if any) indicating that I am exempt from FATCA reporting is correct.

Certification instructions. You must cross out item 2 above if you have been notified by the IRS that you are currently subject to backup withholding because you have failed to report all interest and dividends on your tax return. For real estate transactions, item 2 does not apply. For mortgage interest paid, acquisition or abandonment of secured property, cancellation of debt, contributions to an individual retirement arrangement (IRA), and, generally, payments other than interest and dividends, you are not required to sign the certification, but you must provide your correct TIN. See the instructions for Part II, later.

Sign Here	Signature of U.S. person	Date 1/7/2025
------------------	--------------------------	----------------------

General Instructions

Section references are to the Internal Revenue Code unless otherwise noted.

Future developments. For the latest information about developments related to Form W-9 and its instructions, such as legislation enacted after they were published, go to www.irs.gov/FormW9.

What's New

Line 3a has been modified to clarify how a disregarded entity completes this line. An LLC that is a disregarded entity should check the appropriate box for the tax classification of its owner. Otherwise, it should check the "LLC" box and enter its appropriate tax classification.

New line 3b has been added to this form. A flow-through entity is required to complete this line to indicate that it has direct or indirect foreign partners, owners, or beneficiaries when it provides the Form W-9 to another flow-through entity in which it has an ownership interest. This change is intended to provide a flow-through entity with information regarding the status of its indirect foreign partners, owners, or beneficiaries, so that it can satisfy any applicable reporting requirements. For example, a partnership that has any indirect foreign partners may be required to complete Schedules K-2 and K-3. See the Partnership Instructions for Schedules K-2 and K-3 (Form 1065).

Purpose of Form

An individual or entity (Form W-9 requester) who is required to file an information return with the IRS is giving you this form because they

NON-COLLUSION AFFIDAVIT

I, Sandra M. Sabatier, depose and say that:

1. I am Secretary of the firm Zabatt Engine Services, Inc. the firm submitting the response described in this Request for Proposals; and that I executed the said response with full authority to do so;
2. The prices in this bid have been arrived at independently without collusion, consultation, communication, or agreement for the purpose of restricting competition, as to any matter relating to such prices with any other bidder or with any competitor;
3. Unless otherwise required by law, the prices which have been quoted in this bid have not been knowingly disclosed by the bidder and will not knowingly be disclosed by the bidder prior to bid opening, directly or indirectly, to any other bidder or to any competitor;
4. No attempt has been made or will be made by the bidder to induce any other person, partnership, or corporation to submit, or not to submit, a bid for the purpose of restricting competition; and
5. The statements contained in this affidavit are true and correct, and made with full knowledge that the Town of Ponce Inlet relies upon the truth of the statements contained in this affidavit in awarding contracts for said project.

Bidder's Signature

2/26/2025
Date Signed

STATE OF: Florida COUNTY OF: Duval

The foregoing instrument was acknowledged before me by means of physical presence or online notarization
this 26th day of February, ~~2024~~ 2025 by Sandra M. Sabatier

_____ as authorized representative of the bidder agency submitting this packet.

Notary Signature

Notary Stamp/Seal

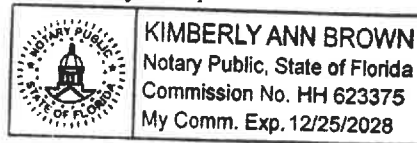

Personally known OR _____ Produced Identification:
Type of ID presented: _____

Town of Ponce Inlet RFP Form

Public Works Emergency Generator

REQUEST FOR PROPOSAL #2025-02 (RFP #2025-02)

Scope of Work:

The Town of Ponce Inlet is requesting a proposal for an emergency generator for the Public Works compound located at 4875 South Peninsula Drive, Ponce Inlet Florida 32127. Proposals shall be submitted based on the purchase, installation, and integration of a 40Kw standby generator. The 40Kw generator can be either diesel or propane powered.

The Generator will be relocated on site to accommodate the addition of a new building. The main electrical service to the compound and transfer switch will need to be relocated as part of this project to also accommodate the addition of a new building. Activities will be completed in strict compliance with Federal, State and Local Codes and Regulations.

The Generator shall be designed/constructed/installed in accordance with the 2023 Florida Building Code and 2020 NEC.

The contractor will be responsible for the permit and engineering to move the main electrical feed and transfer switch to install and integrate the generator into the Public Works main building. After completion of the integration of the generator the contractor will provide a one-hour training session about the generator for Public Works staff.

Deadline:

Please return this Request for Proposal Form addressed to Town Clerk, Town of Ponce Inlet, 4300 S. Atlantic Avenue, Ponce Inlet, FL 32127 in a SEALED ENVELOPE plainly marked on the outside "RFP 2025-02 Public Works Emergency Generator" with a Lump Sum Price by **2:00 pm, Friday, February 28, 2025.**

Lump Sum/Unit Pricing:

ITEM NO.	DESCRIPTION	EST QUANTITY	UNIT	AMOUNT PROPOSAL
1	40Kw Generator	1	LS	65,000 ⁰⁰
2	Move main power feed	1	LS	28,950 ⁵
3	Alternate for New Transfer Switch	1	LS	15,000 ⁰⁰
LUMP SUM TOTAL				108,950⁰⁰

NOTE: This is for LUMP SUM COST of the entire project, unit prices are to establish pricing if additional work is required above or beyond the Lump Sum Base Price.

Vendor Name:	DDS Enterprises LLC	Date:	2/20/25
Company:	"		
Phone #:	386 496 5631	eMail:	DDS Enterprises LLC@yqled
Signature:		Print Name:	Nick Shephard

Attachment F

Certification Regarding
Debarment, Suspension, Ineligibility
And Voluntary Exclusion

Subcontractor Covered Transactions

- (1) The prospective subcontractor, Florida Elec Solutions, of the Recipient certifies, by submission of this document, that neither it nor its principals is presently debarred, suspended, proposed for debarment, declared ineligible, or voluntarily excluded from participation in this transaction by any Federal department or agency.
- (2) Where the Recipient's subcontractor is unable to certify to the above statement, the prospective subcontractor shall attach an explanation to this form.

SUBCONTRACTOR:

Florida Electrical Solutions

By: [Signature]
Signature

Recipient's Name

Bobby Rush
Name and Title

DEM Contract Number

739 N. Volusia Ave, OC.
Street Address

RFP-2025-02-0-2025/05
Project Number

Orange City, FL
City, State, Zip

2/19/25
Date

NON-COLLUSION AFFIDAVIT

I, Nicholas M. Shepard, depose and say that:

1. I am VP of the firm DDS Enterprises LLC, the firm submitting the response described in this Request for Proposals; and that I executed the said response with full authority to do so;
2. The prices in this bid have been arrived at independently without collusion, consultation, communication, or agreement for the purpose of restricting competition, as to any matter relating to such prices with any other bidder or with any competitor;
3. Unless otherwise required by law, the prices which have been quoted in this bid have not been knowingly disclosed by the bidder and will not knowingly be disclosed by the bidder prior to bid opening, directly or indirectly, to any other bidder or to any competitor;
4. No attempt has been made or will be made by the bidder to induce any other person, partnership, or corporation to submit, or not to submit, a bid for the purpose of restricting competition; and
5. The statements contained in this affidavit are true and correct, and made with full knowledge that the Town of Ponce Inlet relies upon the truth of the statements contained in this affidavit in awarding contracts for said project.

KS
Bidder's Signature

2/19/25
Date Signed

STATE OF: Florida COUNTY OF: Volusia

The foregoing instrument was acknowledged before me by means of physical presence or online notarization
this 19th day of Feb, 2025, by Nicholas M. Shepard
as authorized representative of the bidder agency submitting this packet.

[Signature]
Notary Signature

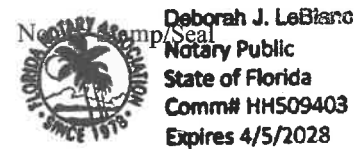

Personally known OR Produced Identification: _____
Type of ID presented: _____

Request for Taxpayer Identification Number and Certification

**Give Form to the
requester. Do not
send to the IRS.**

▶ Go to www.irs.gov/FormW9 for instructions and the latest information.

Print or type.
See Specific Instructions on page 3.

1 Name (as shown on your income tax return). Name is required on this line; do not leave this line blank.	
2 Business name/disregarded entity name, if different from above DDS ENTERPRISES LLC	
3 Check appropriate box for federal tax classification of the person whose name is entered on line 1. Check only one of the following seven boxes.	4 Exemptions (codes apply only to certain entities, not individuals; see instructions on page 3): Exempt payee code (if any) _____ Exemption from FATCA reporting code (if any) _____ <i>(Applies to accounts maintained outside the U.S.)</i>
<input type="radio"/> Individual/sole proprietor or single-member LLC	<input type="radio"/> C Corporation
<input type="radio"/> Limited liability company. Enter the tax classification (C=C corporation, S=S corporation, P=Partnership) ▶ S Note: Check the appropriate box in the line above for the tax classification of the single-member owner. Do not check LLC if the LLC is classified as a single-member LLC that is disregarded from the owner unless the owner of the LLC is another LLC that is not disregarded from the owner for U.S. federal tax purposes. Otherwise, a single-member LLC that is disregarded from the owner should check the appropriate box for the tax classification of its owner.	<input type="radio"/> S Corporation
<input type="radio"/> Other (see instructions) ▶	<input type="radio"/> Partnership
<input type="radio"/> Trust/estate	
5 Address (number, street, and apt. or suite no.) See instructions. 463 Shaw Lake Road	Requester's name and address (optional)
6 City, state, and ZIP code Pierson, FL 32180	
7 List account number(s) here (optional)	

Part I Taxpayer Identification Number (TIN)

Enter your TIN in the appropriate box. The TIN provided must match the name given on line 1 to avoid backup withholding. For individuals, this is generally your social security number (SSN). However, for a resident alien, sole proprietor, or disregarded entity, see the instructions for Part I, later. For other entities, it is your employer identification number (EIN). If you do not have a number, see *How to get a TIN*, later.

Note: If the account is in more than one name, see the instructions for line 1. Also see *What Name and Number To Give the Requester* for guidelines on whose number to enter.

Social security number											
or											
Employer identification number											
8	8	-	1	2	3	6	7	3	8		

Part II Certification

Under penalties of perjury, I certify that:

1. The number shown on this form is my correct taxpayer identification number (or I am waiting for a number to be issued to me); and
2. I am not subject to backup withholding because: (a) I am exempt from backup withholding, or (b) I have not been notified by the Internal Revenue Service (IRS) that I am subject to backup withholding as a result of a failure to report all interest or dividends, or (c) the IRS has notified me that I am no longer subject to backup withholding; and
3. I am a U.S. citizen or other U.S. person (defined below); and
4. The FATCA code(s) entered on this form (if any) indicating that I am exempt from FATCA reporting is correct.

Certification instructions. You must cross out item 2 above if you have been notified by the IRS that you are currently subject to backup withholding because you have failed to report all interest and dividends on your tax return. For real estate transactions, item 2 does not apply. For mortgage interest paid, acquisition or abandonment of secured property, cancellation of debt, contributions to an individual retirement arrangement (IRA), and generally, payments other than interest and dividends, you are not required to sign the certification, but you must provide your correct TIN. See the instructions for Part II, later.

Sign Here	Signature of U.S. person ▶	Date ▶ 2/20/25
------------------	----------------------------	-----------------------

General Instructions

Section references are to the Internal Revenue Code unless otherwise noted.

Future developments. For the latest information about developments related to Form W-9 and its instructions, such as legislation enacted after they were published, go to www.irs.gov/FormW9.

Purpose of Form

An individual or entity (Form W-9 requester) who is required to file an information return with the IRS must obtain your correct taxpayer identification number (TIN) which may be your social security number (SSN), individual taxpayer identification number (ITIN), adoption taxpayer identification number (ATIN), or employer identification number (EIN), to report on an information return the amount paid to you, or other amount reportable on an information return. Examples of information returns include, but are not limited to, the following.

- Form 1099-INT (interest earned or paid)

- Form 1099-DIV (dividends, including those from stocks or mutual funds)
- Form 1099-MISC (various types of income, prizes, awards, or gross proceeds)
- Form 1099-B (stock or mutual fund sales and certain other transactions by brokers)
- Form 1099-S (proceeds from real estate transactions)
- Form 1099-K (merchant card and third party network transactions)
- Form 1098 (home mortgage interest), 1098-E (student loan interest), 1098-T (tuition)
- Form 1099-C (canceled debt)
- Form 1099-A (acquisition or abandonment of secured property)

Use Form W-9 only if you are a U.S. person (including a resident alien), to provide your correct TIN.

If you do not return Form W-9 to the requester with a TIN, you might be subject to backup withholding. See What is backup withholding, later.



Addendum #1

Town of Ponce Inlet

Public Works Generator - RFP No. 2025-02

Q&A

1. *What is the estimated construction budget for this project?*

Answer – \$100,000

Please include proof insurance with proposal.

Debbie Stewart, Assistant Deputy Clerk
Addendum #1 – dated 2/06/2025

Proposed Site Plan

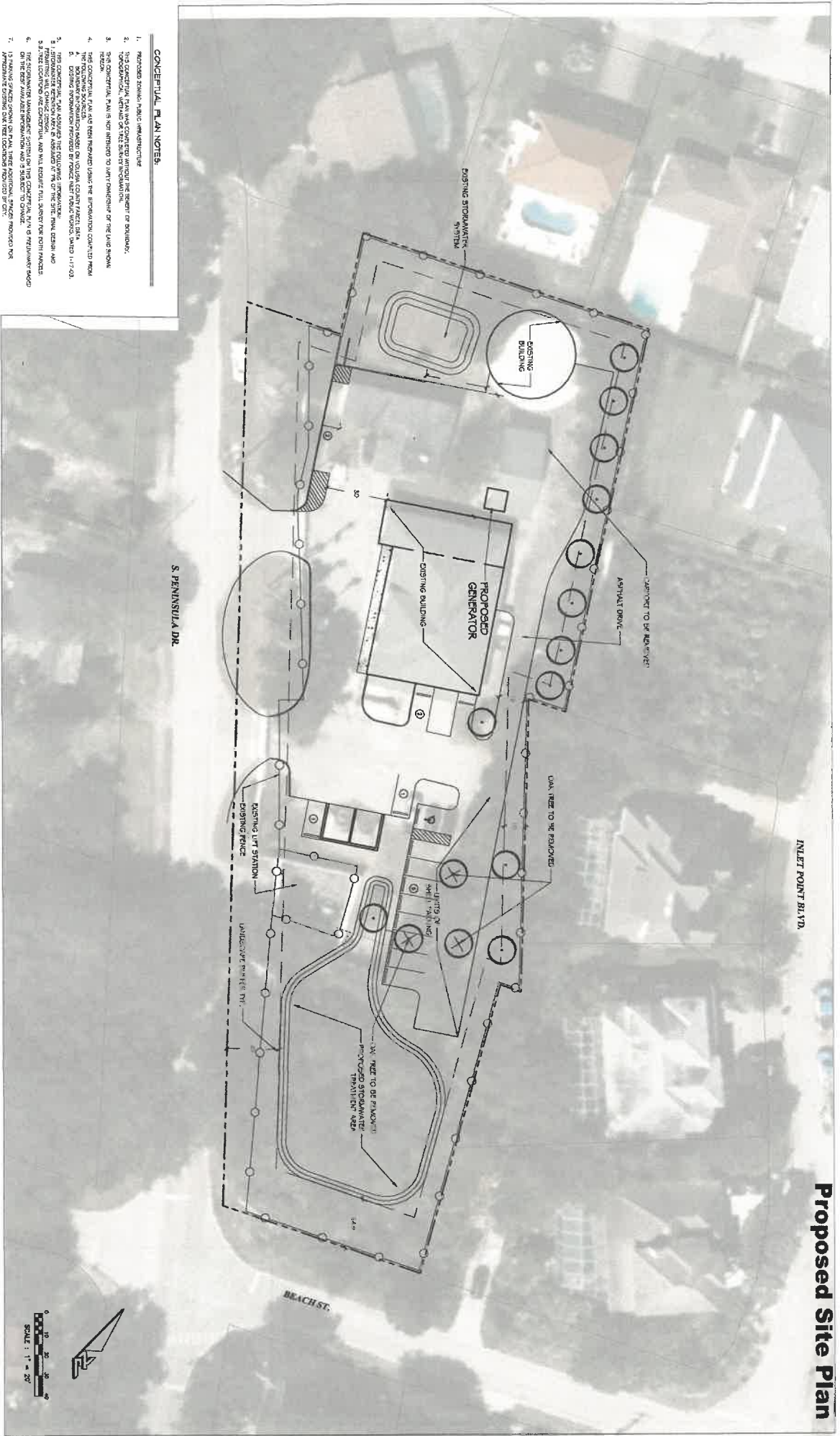

CONCEPTUAL PLAN NOTES:

1. PROPOSED EXISTING TRUCK MANUFACTURER
2. THE CONCEPTUAL PLAN IS FOR THE PROPOSED GENERATOR
3. THE CONCEPTUAL PLAN IS NOT INTENDED TO SHOW DIMENSIONS OF THE LAND FROM THE PLAN.
4. THE CONCEPTUAL PLAN HAS BEEN PROVIDED USING THE INFORMATION COLLECTED FROM THE EXISTING RECORDS AND THE INFORMATION PROVIDED BY THE CLIENT.
5. THE CONCEPTUAL PLAN IS NOT INTENDED TO BE USED AS A BASIS FOR CONSTRUCTION.
6. THE CONCEPTUAL PLAN IS NOT INTENDED TO BE USED AS A BASIS FOR CONSTRUCTION.
7. THE CONCEPTUAL PLAN IS NOT INTENDED TO BE USED AS A BASIS FOR CONSTRUCTION.

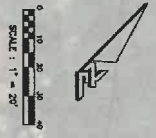

1. LAYOUT: 08/21/2018 2. REVISION: 08/21/2018 3. DATE: 08/21/2018 4. TIME: 10:00 AM 5. PROJECT: INLET POINT BLVD. PROJECT



PONCE INLET PUBLIC WORKS CP2
VOLUSIA COUNTY, FLORIDA



Meeting Date: 3/20/2025

Agenda Item: 15

Report to Town Council

Topic: From the Town Manager

Summary: Please see attached report.

Requested by: Mr. Disher, Town Manager

Approved by: Mr. Disher, Town Manager



MEMORANDUM
OFFICE OF THE TOWN MANAGER

The Town of Ponce Inlet staff shall be professional, caring and fair in delivering community excellence while ensuring Ponce Inlet citizens obtain the greatest value for their tax dollar.

To: Town Council
From: Michael E. Disher, AICP, Town Manager
Date: March 13, 2025
Subject: Town Manager's Report

MEETING DATE: March 20, 2025

1. Volusia County Council meeting on 03-04-25:
 - [Item G](#) – Revisions to the interlocal municipal transport agreements for the five participating EMS agencies, including the cities of Deltona, Edgewater, New Smyrna Beach, and Port Orange, and the Town of Ponce Inlet. The Town Council approved its agreement on January 16, 2025.
 - [Item L](#) – Florida Legislative appropriation requests, totaling \$22,400,000 for a new Sheriff's Office headquarters, resiliency upgrades to Beach Street, security upgrades to the Correction Center, and improvements to the Emergency Operations Center.
 - [Item P](#) - Renewal of Agreement with Best Flood Barriers, LLC for delivery of a temporary on-beach erosion and shoreline protection sandbag system (TrapBags).
2. County Council meeting on 03-18-25:
 - [Item N](#) – Task Assignment with Halff Associates, Inc., for Stormwater Master Plan Program Management Support and Standards Development. This project will create a series of standardized guidelines for stormwater master plan modeling, GIS, file management, quality control, and deliverables to ensure consistency among the countywide stormwater projects.
3. Port Orange City Council meeting on 03-18-25:
 - Water fluoridation – The Council will be discussing whether to continue adding fluorine to its potable water system. The item is No. I-21 on the Port Orange meeting agenda page, at: <https://portorangefl.portal.civicclerk.com/event/2288/overview>. The public may provide comments to Stephanie DiPietrantonio, Executive Assistant to the City Manager at SDipietrantonio@port-orange.org or by phone at (386) 506-5502.

4. Public Works update:

- The contract for the new emergency generator at the Community Center has been approved by FDEM. The generator has been ordered, and work is expected to start in March and be completed by the end of April.
- The work to repair and replace the Ponce Inlet Historical Museum boardwalk begins March 13th. The Museum will be closed during this time, but is expected to reopen on March 26th.
- Staff has been in discussions with Volusia County Road & Bridge Division about constructing the new swales on S. Atlantic Avenue as recommended in the Watershed Master Plan. County staff has reviewed the Plan and is willing to complete the work. They will be putting a plan together to accomplish this over the next several years. County staff will coordinate this work with the Town in terms of priority and will request official support before proceeding.

5. Building permit activity:

	Jan	Feb	Mar	Apr	May	Jun	Jul	Aug	Sep	Oct	Nov	Dec	Total	Avg
Permit applications	123	122											245	123
Permits issued	90	111											201	101
Plan reviews	93	113											206	103
Inspections	246	236											482	241

6. The Planning & Development Department’s Senior Planner, Bernadette Fisher, resigned last month. The position has been advertised and interviews are being scheduled.
7. Dr. Parida and his team from ERAU submitted the grant application for a Living Seawall at Ponce Preserve to the National Science Foundation on 03-03-25. The decision on the grant award is expected this July or August.
8. Staff has submitted a list of projects to Volusia County’s Transform386 program for the next round of infrastructure funding. These projects were identified in the Watershed Master Plan and include other locally identified needs that are not urgent in nature, such as:
- Improved drainage for flood-prone segments of S. Atlantic Ave. and S. Peninsula Dr.
 - Design and construction of a new fire station
 - A living seawall for the rest of Ponce Preserve oceanfront
 - Expansion and enhancement of our stormwater drainage system.
 - Additional one-way flap valves for storm drains on low-lying streets.
- The County will be holding a workshop with prospective grant applicants on April 4th to discuss the application process and timeframes.
9. I.T. has been working over the past several months to fix and upgrade the sound equipment in the Council Chambers. Some of this equipment was overdue for replacement and other components had stopped working properly. This has made a noticeable difference in sound quality.